

Deerfield Pellet Stove

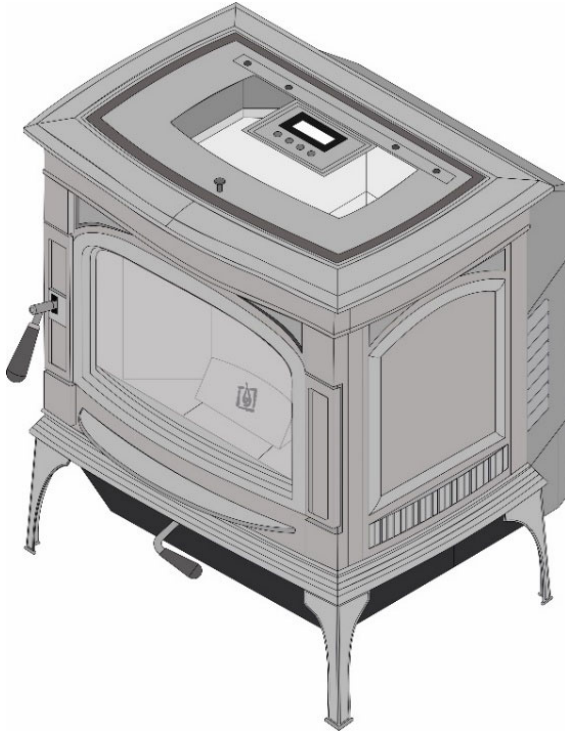

- *Horizontal or Vertical Vent*
- *Freestanding Stove*
- *Mobile Home Approved*
- *Class A Chimney Retrofit*
- *Hearth Stove into Existing Masonry Chimney, Masonry Fireplace, or Z.C. Fireplace*

-- **Please read this entire manual before installation and use of this pellet fuel-burning room heater. Failure to follow these instructions could result in property damage, bodily injury, or even death.**

-- **Contact local building or fire officials about restrictions and installation inspection requirements in your area.**

-- **Save these instructions.**



⚠ WARNING



**HOT GLASS WILL CAUSE BURNS.
DO NOT TOUCH GLASS UNTIL COOLED.
NEVER ALLOW CHILDREN TO TOUCH GLASS.**

Installer: After installation give this manual to the homeowner and explain the operation of this heater.

Consumer: Retain this manual for future reference.

\$10.00 © Copyright 2022, T.I.
Part # 100-01550 3/28/23



**TRAVIS INDUSTRIES
HOUSE OF FIRE**
www.travisproducts.com
12521 Harbour Reach Drive SW
Mukilteo, WA 98275

Introduction

We welcome you as a new owner of a Deerfield pellet stove. In purchasing a pellet stove you have joined the growing ranks of concerned individuals whose selection of an energy system reflects both a concern for the environment and aesthetics. The Deerfield pellet stove is one of the finest home heaters the world over. This manual will explain the installation, operation, and maintenance of this pellet-burning heater. Please familiarize yourself with this Owner's Manual before operating your heater and save the manual for future reference. Included are helpful hints and suggestions which will make the installation and operation of your new heater an easier and more enjoyable experience. We offer our continual support and guidance to help you achieve the maximum benefit and enjoyment from your heater.

Important Information

No other Deerfield pellet stove has the same serial number as yours. The serial number is on the safety label on the back of the appliance.

This serial number will be needed in case you require service of any type.

Model: Deerfield

Serial Number: _____

Purchase Date: _____

Purchased From: _____

Register your warranty online at:

traviswarranty.com

Save Your Bill of Sale.

To receive full warranty coverage, you will need to show evidence of the date you purchased your heater.

We suggest that you attach your Bill of Sale to this page so that you will have all the information you need in one place should the need for service or information occur.



NATIONAL FIREPLACE INSTITUTE
NFI
CERTIFIED
www.nficertified.org

We suggest that our pellet hearth products be installed and serviced by professionals who are certified in the U.S. by the National Fireplace Institute® (NFI) as NFI Pellet Specialists or who are certified in Canada by Wood Energy Technical Training (WETT).



Wood Energy Technical Training
www.wettinc.ca

| | | | |
|---|-----------|--|-----------|
| Introduction | 2 | External Thermostat Installation | 15 |
| Important Information | 2 | Installation Examples | 16 |
| Heating Specifications | 7 | Safety Notice | 22 |
| Dimensions | 7 | Touch Screen Controls | 22 |
| Electrical Specifications | 7 | Loading Pellets | 23 |
| Fuel | 7 | Starting the Heater for the First Time | 23 |
| Emissions | 7 | Simple Mode vs Advance Mode | 24 |
| Efficiency | 7 | Simple Mode –Options | 25 |
| Before You Begin | 8 | Simple Mode - Operation | 26 |
| Packing List | 8 | Fan Setting | 28 |
| Installation Options | 8 | Dealer Service Mode: | 29 |
| Planning the Installation | 9 | Advanced Mode –Options | 30 |
| Stove Placement | 9 | Advance Mode - Operation | 30 |
| Floor Protection Requirements | 9 | Thermostat Programs | 32 |
| Electrical Requirements | 9 | Fan Setting | 33 |
| Clearances | 10 | Heater Status | 34 |
| Straight Installations | 10 | Menu Button | 35 |
| Corner Installations | 10 | T-Stat Idle Mode | 35 |
| Venting the Pellet Stove | 11 | Screen Lock | 36 |
| Maximum Venting Distance | 11 | Dealer Service Mode: | 36 |
| Pellet Vent Type | 12 | Menu Flow Chart | 37 |
| Installing the Pellet Vent | 12 | Power Outages | 38 |
| Pellet Vent Termination | 12 | Normal Operating Sounds | 38 |
| Mobile Home Requirements | 13 | Stove Maintenance | 39 |
| Outside Air (Used for Combustion – Part #99200139) | 13 | Monthly Maintenance (while appliance is in use) ... | 48 |
| Alcove Installation Requirements | 14 | Door Parts | 53 |
| Restrictor Adjustment | 14 | Wiring Diagram | 55 |

Safety Precautions



**HOT WHILE IN OPERATION.
KEEP CHILDREN, CLOTHING,
AND FURNITURE AWAY.
CONTACT MAY CAUSE SKIN
BURNS.**

Educate all children of the danger of a high-temperature heater. Young children should be supervised when they are in the same room as the



Contact your local building officials to obtain a permit and information on any installation restrictions or inspection requirements in your area. Notify your insurance company of this appliance as well.



Do not operate the heater if you smell smoke coming from the heater. Press the "STOP" button, monitor your heater, and call your dealer.



Never use gasoline, gasoline-type lantern fuel, kerosene, charcoal lighter fluid, or similar liquids to start or "freshen up" a fire in this heater. Keep all such liquids well away from the heater while it is in use.



Do not unplug the heater if you suspect a malfunction. Press the "STOP" button and periodically inspect the heater.



Do not store solid fuel or place such fuel within heater installation clearances or within the space required for charging and ash removal.

Ashes should be placed in a metal container with a tight-fitting lid. The closed container of ashes should be placed on a noncombustible floor or on the ground, well away from all combustible materials, pending final disposal. If the ashes are disposed of by burial in soil or otherwise locally dispersed, they should be retained in the closed container until all cinders have been thoroughly cooled.

Do not alter this appliance in any way.



Never try to repair or replace any part of the heater unless instructions are given in this manual. All other work should be done by a trained technician.



The viewing door and ashpan must be closed and latched during operation.



This unit must be properly installed to prevent the possibility of a house fire. The instructions must be strictly adhered to. Do not use makeshift methods or compromise in the installation.



This heater is designed and approved for pelletized wood fuel only.

Never burn unseasoned wood, treated wood, colored paper, cardboard, solvents, trash or garbage in this appliance.

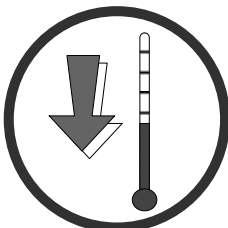

Allow the appliance to cool completely before carrying out any maintenance or cleaning.



Maintain the door and glass seal and keep them in good condition.

Do not operate this heater with broken or missing glass.

Do not slam the door or strike the glass.

Notify your dealer to replace the glass if the glass on this appliance is broken or damaged.



Do not operate the heater if the flame becomes dark and sooty or if the burn platform overfills with pellets. Press the "STOP" button and periodically inspect the heater.

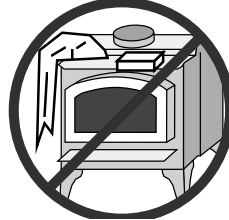

Do not place clothing or other flammable items on or near this appliance.



The heater will not operate during a power outage.



This heater must be connected to a standard 115 V., 60 Hz grounded electrical outlet. Do not use an adapter plug or sever the grounding plug. Do not route the electrical cord underneath, in front of, or over the heater.



Keep foreign objects out of the hopper.



The exhaust system must be completely airtight and properly installed. The pellet vent joints must be sealed with RTV 500° F. (260° C.) silicone sealant.



Your heater requires periodic maintenance and cleaning (see "Heater Maintenance"). Failure to maintain your heater may lead to accumulation of soot, creosote, and ash, and smoke spillage or fire in your home.



When installed in a mobile home, the heater must be bolted to the floor, have outside air, and NOT BE INSTALLED IN THE BEDROOM (per H.U.D. requirements). Check with local building officials.



Do not throw this manual away. This manual has important operating and maintenance instructions that you will need at a later time. Always follow the instructions in this manual.



Disconnect the power before performing any maintenance.



The exhaust system should be checked at least twice a year for any build-up of soot or creosote.



Travis Industries, Inc. grants no warranty, implied or stated, for the installation or maintenance of your appliance, and assumes no responsibility for any consequential damage(s).

Safety Precautions

DO NOT INSTALL A FLUE DAMPER IN THE EXHAUST VENTING SYSTEM OF THIS UNIT.

DO NOT CONNECT THIS UNIT TO A CHIMNEY FLUE SERVING ANOTHER APPLIANCE.

INSTALL VENT AT CLEARANCES SPECIFIED BY THE VENT MANUFACTURER.

Soot and Flyash: Formation and Need for Removal – The products of combustion will contain small particles of flyash. The flyash will collect in the exhaust venting system and restrict the flow of the flue gases. Incomplete combustion, such as occurs during startup, shutdown, or incorrect operation of the room heater will lead to some soot formation that will collect in the exhaust venting system. The exhaust venting system should be inspected at least twice every year to determine if cleaning is necessary.

NEVER USE SUBSTITUTE MATERIALS FOR ANY PURPOSE ON THIS APPLIANCE.

Establish a routine for fuel and firing technique. Check for creosote build-up daily until you know how often to clean the appliance for safe operation. Be aware that the hotter the fire, the less creosote is deposited, and weekly cleaning may be necessary in mild weather even though monthly cleaning may be enough in the coldest months. Contact your municipal or provincial fire authority for information on how to handle a chimney fire. Have a clearly understood plan in place for how to handle a chimney fire.

Do not burn this heater if unburned pellets are in the ashpan. These should be removed as they may ignite.

Smoke and CO Detectors: Make sure your home has a working smoke detector, especially near any bedrooms. We recommend having a smoke and/or CO detector in the same room as the wood heater for additional safety.

Proposition 65 Warning: Fuels used in gas, woodburning or oil-fired appliances, and the products of combustion of such fuels, contain chemicals known to the State of California to cause cancer, birth defects, and other reproductive harm. California Health & Safety Code Sec. 25249.6

This wood heater has a manufacturer-set minimum low burn rate that must not be altered. It is against federal regulations to alter this setting otherwise operate this wood heater in a manner inconsistent with operating instructions in this Manual.

U.S. and Foreign Patents Pending.

Heating Specifications

| | |
|---|----------------------|
| Approximate Maximum Heating Capacity (in square feet) * | Up to 2,500 Sq. Feet |
| BTUs Per Hour (net input) | 14,781 to 44,344 |
| BTUs Per Hour (net output) | 10,916 to 35,779 |
| Overall Efficiency (LHV) | 83.2% |
| Overall Efficiency (HHV) | 77% |
| Burn Rate (Pounds per Hour) ** | 1.7 to 6 |
| Maximum Burn Time on Low Burn** | 35 Hours |
| Hopper Capacity | 60 Pounds |
| Turn-Down Ratio | 67% |

* Heating capacity will vary depending on the home's floor plan, degree of insulation, and the outside temperature. It is also affected by the fuel size, quality, and moisture level.

** Small pellet size will decrease the stated burn rates and burn times. Differences of plus or minus 20% depending on fuel quality may occur.

Dimensions

WEIGHT: 400 lbs. (181 Kg)

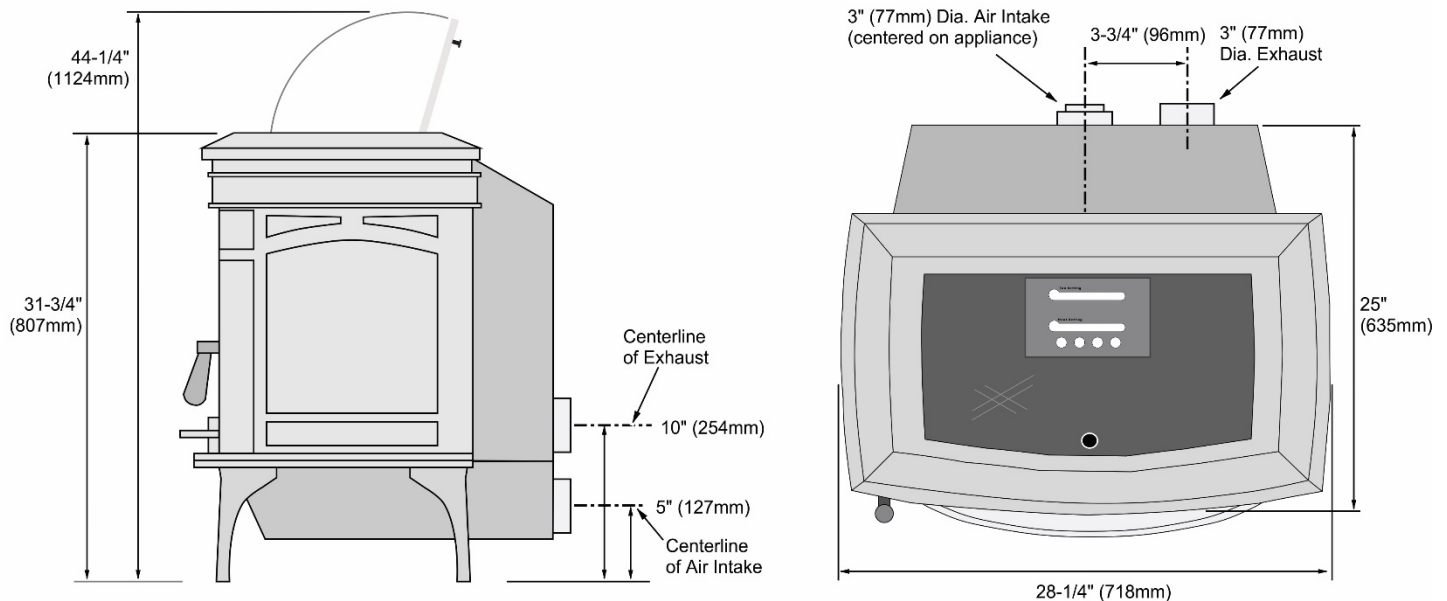

Electrical Specifications

| | |
|--------------------------------|--------------------------|
| Electrical Rating | 115 Volts, 4 Amps, 60 Hz |
| Watts during Start-Up Sequence | 480 (approximately) |
| Watts during Operation | 300 (approximately) |

Fuel

This heater is designed and approved for pelletized wood fuel only (all grades). Travis Industries Inc. recommends using only fuel that is certified by the Pellet Fuels Institute (PFI).

Emissions

This heater meets the 2020 U.S. EPA's emission limits for pellet heaters. Report# 0028PS107E.REV001 Tested to ASTM E2779-10, ASTM2515, CSAB415.1-10 This heater has been shown to deliver heat at input rates ranging from 10,916 to 35,779 BTU/hr. net output, and emission value of 1.23g/h.



Efficiency

This model was tested for efficiency using method B415.1-10 and was determined to have a weighted average Higher heating value (HHV) Overall Heating Efficiency (OHE) of 77%.

Before You Begin

READ THIS ENTIRE MANUAL BEFORE YOU INSTALL AND USE THIS HEATER. FAILURE TO FOLLOW THE INSTRUCTIONS MAY RESULT IN PROPERTY DAMAGE, BODILY INJURY, OR EVEN DEATH.

Check with local building officials for any permits required for the installation of this pellet heater and notify your insurance company before proceeding with the installation.

Packing List

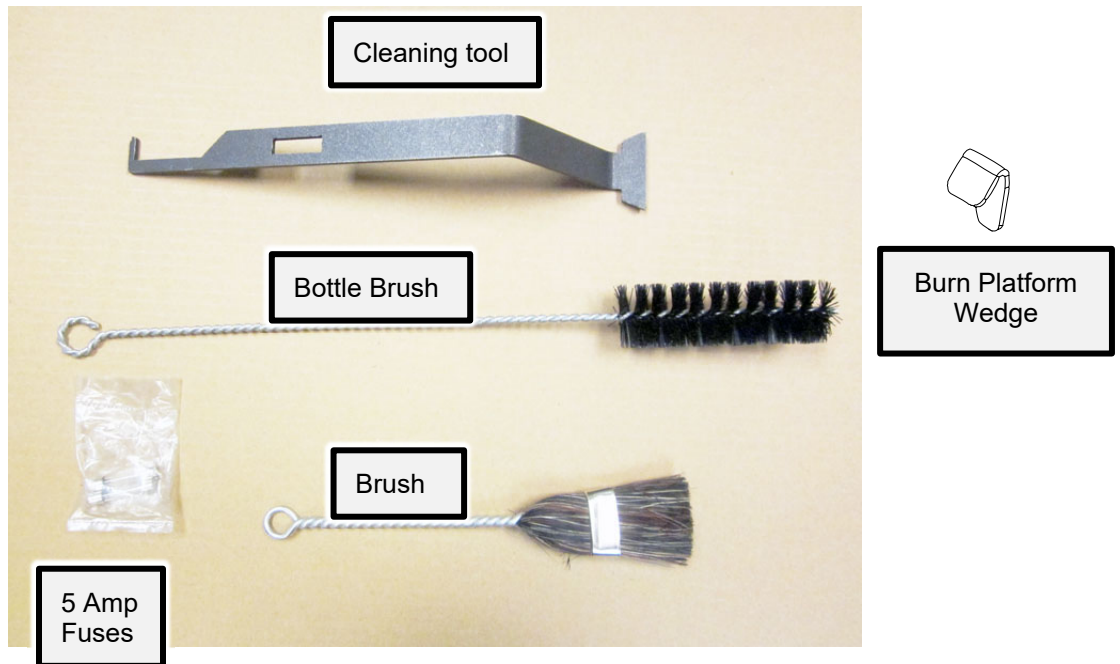

Installation Options

- Residential or Mobile Home (see the section "Mobile Home Requirements")
- Alcove Compatible (see the section "Alcove Installation")
- Horizontal or Vertical Vent
- Outside Air Compatible
- Vent with L-Vent, L-Vent Fireplace Liner, or Type "A" Chimney (with adapter)

Planning the Installation

- HINT: Have an authorized Travis Industries dealer install this heater. If you install the heater yourself, have your dealer review your installation plans.
- HINT: Sketch out a detailed plan of the installation including dimensions. Then verify the dimensions with the requirements listed in this manual.
- HINT: When determining the location of the stove, locate the wall studs (for horizontal penetrations) and ceiling trusses (for vertical penetrations). You may wish to adjust the stove position slightly to ensure the vent does not intersect with a framing member.

The location of your wood heater in your home will decide how effectively the heat produced will spread throughout your house. Attention to the home design with consideration of natural convection and air circulation should be taken into account when choosing the placement of your heater within the home.

Stove Placement

- The stove must be placed so that no combustibles are within, or can swing within (e.g., drapes, doors), 36" (915mm) of the front of the heater.
- If the stove is placed in a location where the ceiling height is less than 7' (2.134 M), it must follow the requirements in the section "Alcove Installation Requirements".
- Heater and floor protection must be installed on a level, secure floor.

Floor Protection Requirements

- The heater must be installed on a non-combustible floor protector extending the full width and depth of the heater and extending 6" (153mm) in front and sides of fuel loading or ash removal doors (minimum .018" thick - 26 gauge).
- Must extend under and 2" (51mm) to each side and rear of a "Tee" (if used).

Electrical Requirements

- This heater **requires** a standard 120-volt, 60 Hz **grounded** electrical outlet. Do not use an adapter plug or sever the grounding plug.
- This heater **requires correct polarity**. The line (hot) is on the right and has a smaller plug. The neutral (common) is on the left and has a larger plug. Use a circuit tester (available at hardware stores) or contact an electrician to verify correct polarity and ground.

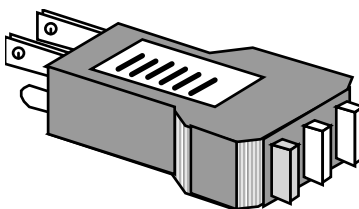

WARNING: Connection to reverse polarity or un-grounded circuit may damage your heater's circuit board. This may cause a safety hazard, improper operation, and void your warranty.

- Do not route the electrical cord underneath, in front of, or over the heater.

Clearances

Straight Installations

NOTE: Front, side, and corner clearances are measured from the edge of the stove top.

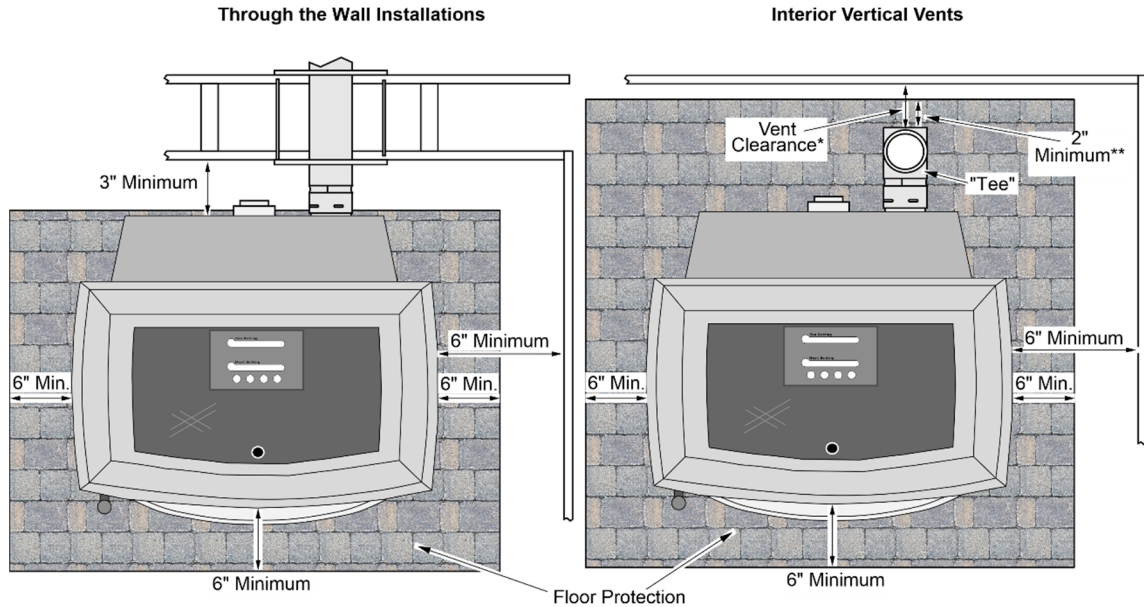

Corner Installations

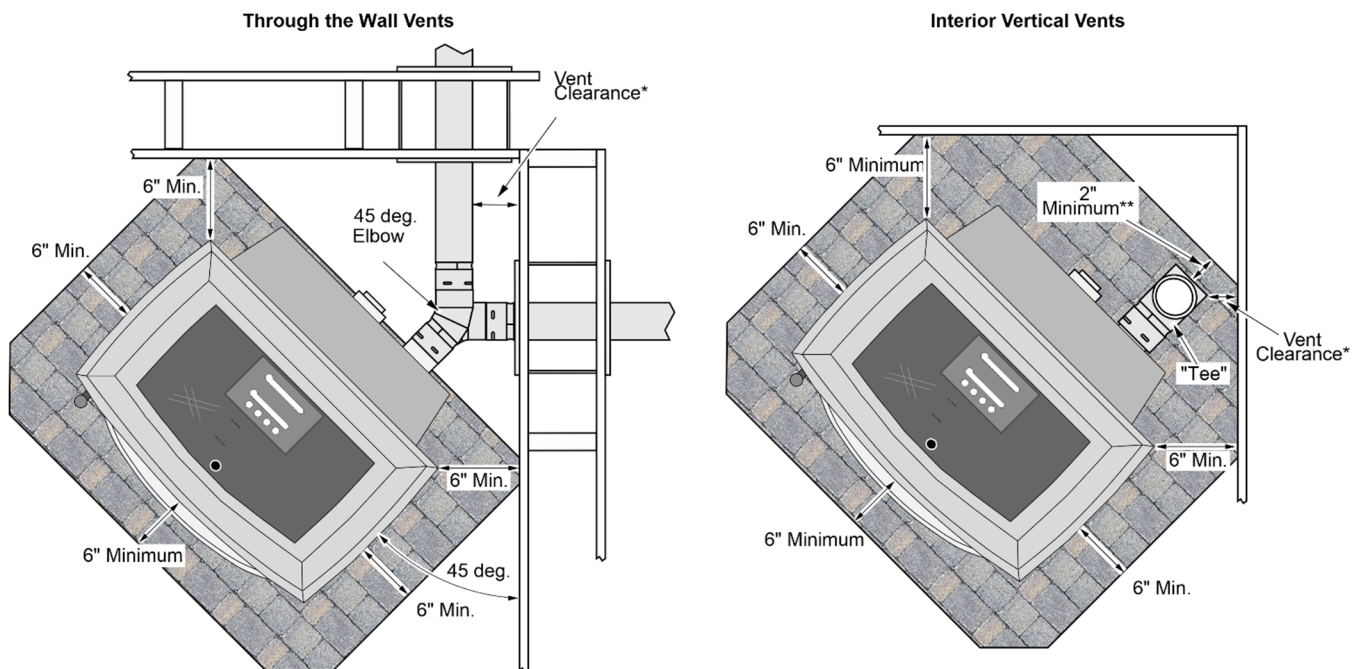

- * **Install the vent at the clearance specified by the vent manufacturer.**

NOTE: If an interior vertical vent is used, the stove to back wall dimension is determined by the vent being used. This dimension will vary depending on the brand of pellet vent used. To determine the distance from the back wall to the stove, connect the "Tee" and add the vent clearance.

- ** The floor protection must extend 2" (51mm) beyond the pipe – all vent clearances must be met.

Venting the Pellet Stove

- INSTALL VENT AT CLEARANCES SPECIFIED BY THE VENT MANUFACTURER.
- DO NOT CONNECT THE PELLETT VENT TO A VENT SERVING ANY OTHER APPLIANCE OR STOVE.
- DO NOT INSTALL A FLUE DAMPER IN THE EXHAUST VENTING SYSTEM OF THIS UNIT.
- USE AN APPROVED WALL THIMBLE WHEN PASSING THE VENT THROUGH WALLS AND A CEILING SUPPORT/FIRE STOP SPACER WHEN PASSING THE VENT THROUGH CEILINGS (MAKE SURE TO MAINTAIN CLEARANCE TO ANY COMBUSTIBLES).
- No more than one tee and 180° of elbows (one tee with two 90° elbows, one tee with one 90° and two 45° elbows, etc.).

Maximum Venting Distance

- Vent must have a support bracket every 5' (1.524 M) of pellet vent when on exterior of structure.

NOTE: Travis Industries recommends a minimum vertical vent of 5' to ensure adequate draft during a power outage.

The vent height and run must not exceed the distance shown in the shaded region indicated to the right

Restrictor adjustment may be required dependent on the vent configuration. See the section "Restrictor Adjustments" for details.

Note: To achieve optimum performance, we recommend keeping the vent as short as possible (horizontal run especially).

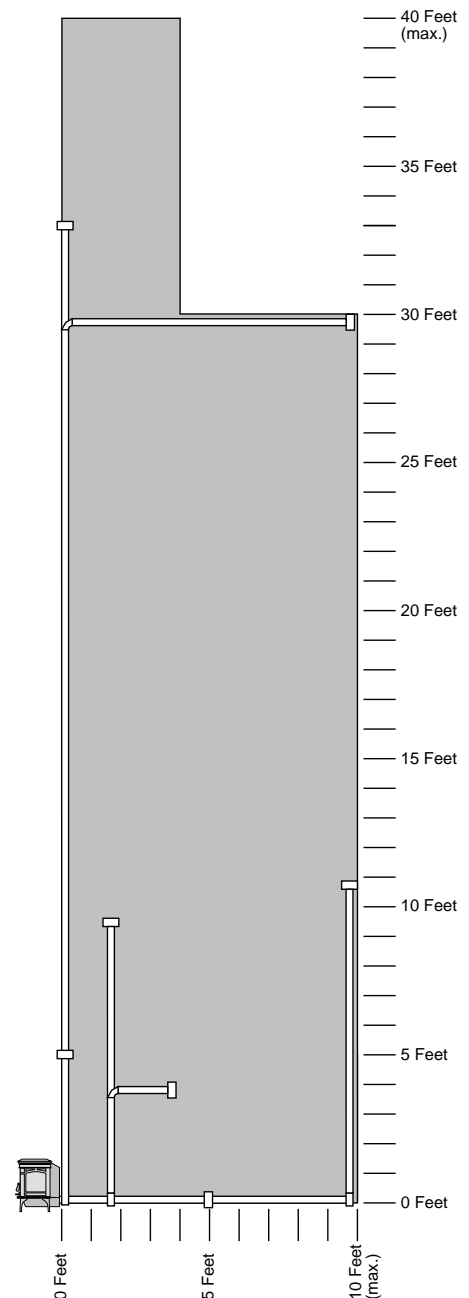

Pellet Vent Type

- Must be 3" (76mm) or 4" (102mm) diameter Type "L" (except for masonry fireplace installations) - or - connect the vent to a factory-built type "A" chimney.

Installing the Pellet Vent



Seal each vent section (including the connection to the heater, adapters, elbows, etc...) following the directions provided by the vent manufacturer or by injecting a liberal amount of 500 deg. F. RTV silicone into the gap between sections.

- Secure each vent section (including the connection to the heater, adapters, elbows, etc...) following the directions provided by the vent manufacturer or by using 3 sheet metal screws (1/4" Max.).
- Horizontal sections must have a 1/4" (6.4mm) rise every 12" (305mm) of travel.
- Install the vent at the clearances specified by the vent manufacturer.

Pellet Vent Termination

- Vent must terminate on the exterior of the dwelling. Horizontal terminations must protrude a minimum of 12" (305mm) from the wall. Vertical terminations must protrude a minimum 24" (610mm) from the roof surface. In addition, all clearances listed below must be met.
- Must have an approved cap (to prevent water from entering) or a 45° downturn with rodent screen.
- If the termination is located on a windy side of the house, an approved house shield is recommended to prevent soot from building up on the side of the house.
- Must not be located where it will become plugged by snow or other material.

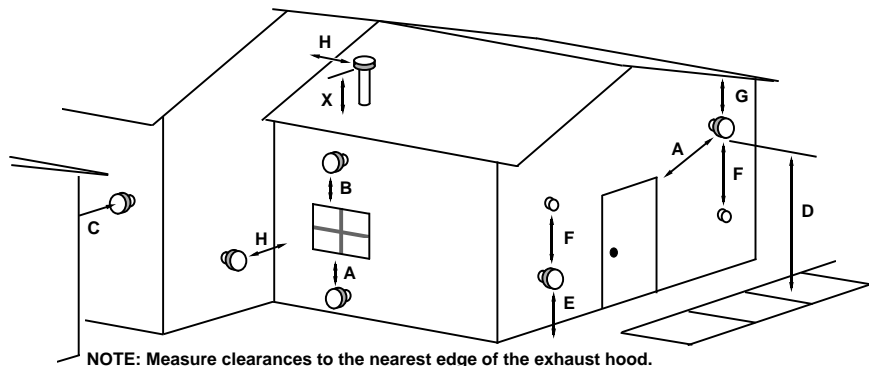

- A Minimum 4' (1220mm) clearance below or beside any door or window that opens. (This clearance may be reduced to 18" if using outside air (see page 13) – we recommend the door or window be kept closed during operation.)
 Minimum 1' (458mm) clearance below or beside any window that does not open.
- B Minimum 1' (458mm) clearance above any door or window that opens
- C Minimum 2' (610mm) clearance from any adjacent building
- D Minimum 7' (2.134 M) clearance above any grade when adjacent to public walkways
- NOTE:** Vent may not terminate in covered walkway or breezeway.
- E Minimum 2' (610mm) clearance above any grass, plants, or other combustible materials
- F Minimum 3' (915mm) clearance from any forced air intake of any other appliance
- G Minimum 2' (610mm) clearance below eaves or overhangs
- H Minimum 1' (458mm) clearance horizontally from combustible wall
- X Must be a minimum of 2' (610mm) above the roof

Mobile Home Requirements

- The stove must be vented using an approved listed pellet vent (sometimes referred to as “L” or “PL” vent pipe).
- The appliance, venting system, and hearth system (if applicable) must be installed in accordance with the terms of their listing and their manufacturer’s instructions.
- Outside Air Kit (sku# 99200139) must be used to duct combustion air directly into the appliance. The kit is available through your dealer.
- The stove must be secured to the floor of the manufactured home. Travis Industries manufactures a kit (sku# 98900509) for securing the appliance. The kit is available through your dealer.
- The appliance must be plugged into a properly grounded outlet.



DO NOT INSTALL IN SLEEPING ROOM.



THE STRUCTURAL INTEGRITY OF THE MANUFACTURED HOME FLOOR, WALL, AND CEILING/ROOF MUST BE MAINTAINED.

Outside Air (Used for Combustion – Part #99200139)



Outside air is strongly recommended. The use of outside air reduces noise levels inside the house and prevents smoke spillage into the home during power outages.

- Must not be drawn from an enclosed space (garage, unventilated crawl space).
HINT: Travis Industries strongly recommends outside air for all residential installations, especially for those that are energy efficient, air-tight homes, or when using vent without rise.
- Must not be over 48” (1220mm) long
- Must be made with 3” (76mm) diameter or larger metal or aluminum duct with a metal screen attached to the end to keep out rodents (P.V.C. or other combustible materials may not be used). We recommend the Travis Industries Outside Air Kit (part # 99200139).
- Must not terminate above or within 1’ (305mm) of the chimney termination.
- Must have a rain cap or down-turned elbow to prevent water from entering.
- Must be located so that it will not become plugged by snow or other material.

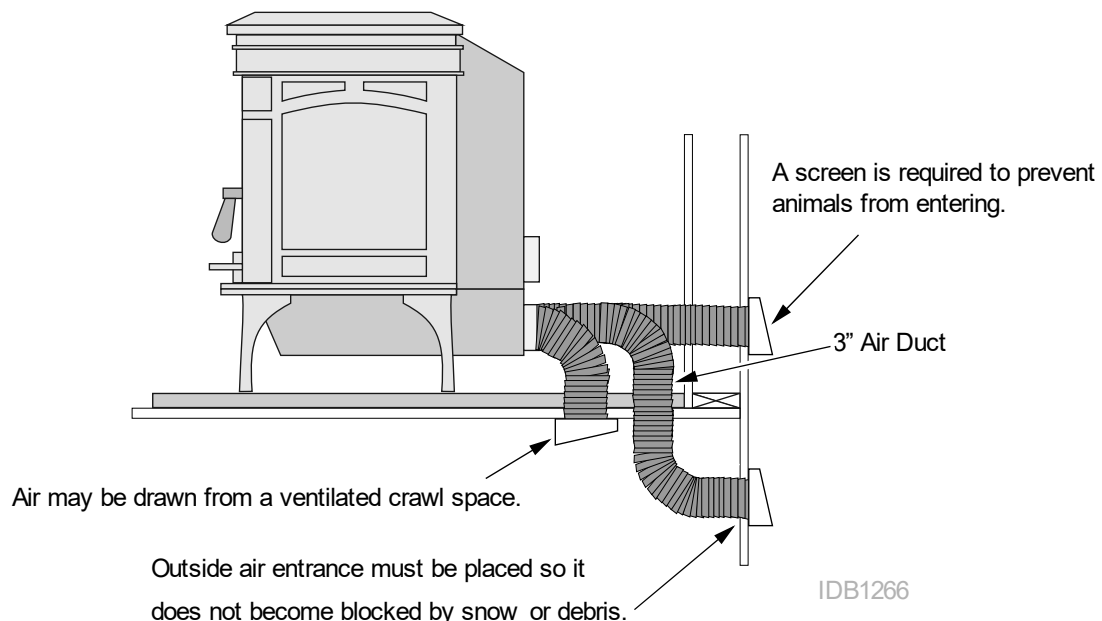

Alcove Installation Requirements

When the pellet stove is placed in a location where the ceiling height is less than 7' (2.134 M) tall, it is considered an alcove installation. Because of the reduced height, the requirements listed below must be met.

| | |
|-----------------------|-----------------|
| Minimum Width | 40-1/4"(1023mm) |
| Maximum Depth | 48" (1220mm) |
| Minimum Height | 60"(1524mm) |

Restrictor Adjustment

For installations with a tall flue, the restrictor may be needed to adjust airflow to the burn platform. This keeps the burn platform and glass as clean as possible.

For low heat output settings, the restrictor may need to be closed or near closed to limit the amount of air. This helps prevent the heater from burning the pellet fuel faster than it is fed.

For medium heat output settings, the restrictor may need to be opened to a medium position.

For high heat output settings, the restrictor may need to be opened to a high position. This helps prevent the burn platform from over-filling with pellets and becoming clogged with ash clumps.

Keeping your burn platform clean is the most important step to maintaining a safe and efficient heater. Check and clean your burn platform daily until you find the correct restrictor settings and appropriate burn platform cleaning interval.

Not Enough Air

If clinkers (ashes that solidify into a clump) develop or the flame appears lazy and slow to blow the ash out of the burn platform, push the restrictor in until the flame becomes active, and the burn platform holes remain clean.

NOTE: If the restrictor is fully in, yet the burn platform does not remain clean, the heater should be cleaned and checked for air leaks (see "Maintenance" section of this manual).



Too Much Air

If the flames are too active (small, flickering flames), move the restrictor out until the flame slows down.

NOTE: It is acceptable to have "glowing embers" jump out of the burn platform. Another symptom of too much air is the heater "blowing the fire out" – a condition in which the pellets burn faster than they are fed (this is most common on low heat settings).



More Air

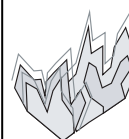

Less Air



External Thermostat Installation

- This heater may be used with an external thermostat or remote.



WARNING: Use only a dry-contact thermostat or remote (also called millivolt thermostat/remote). The use of a voltage producing thermostat (24v, 120v AC, etc.) will damage the appliance.

- Connect the leads from the thermostat to the two quick-connect tabs on the back of the heater.

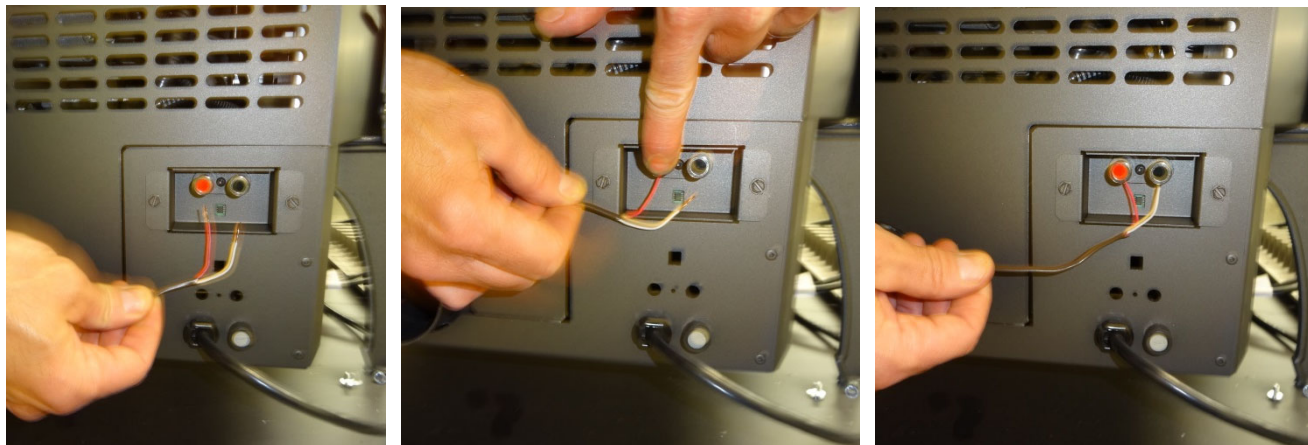

Once the external thermostat is installed, you will need to configure the heater to disable the internal thermostat. See the instructions on page 32.

Installation Examples

Installation Example: Direct "Through-the-wall" Installation

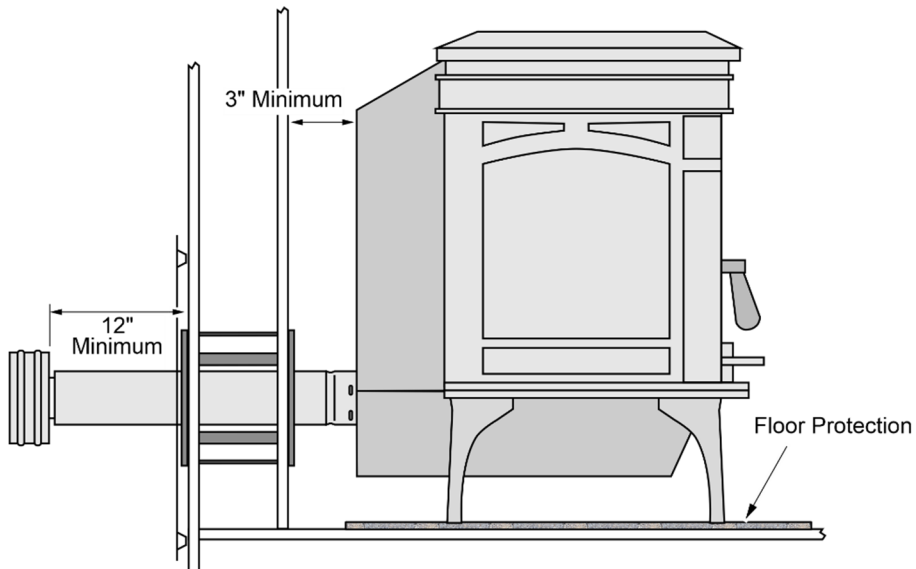
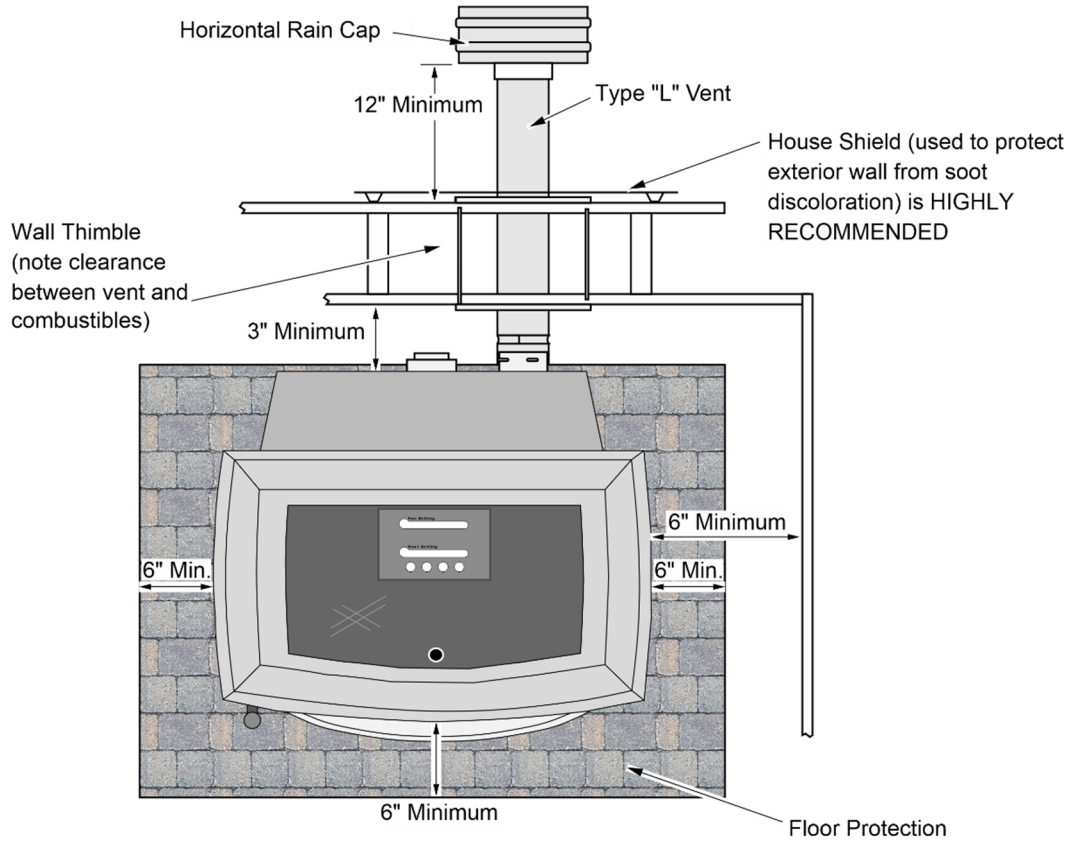

NOTE: Travis Industries recommends a minimum vertical vent of 5' to ensure adequate draft during a power outage.

Install the vent at the clearance specified by the vent manufacturer.

Class A Chimney Retrofit

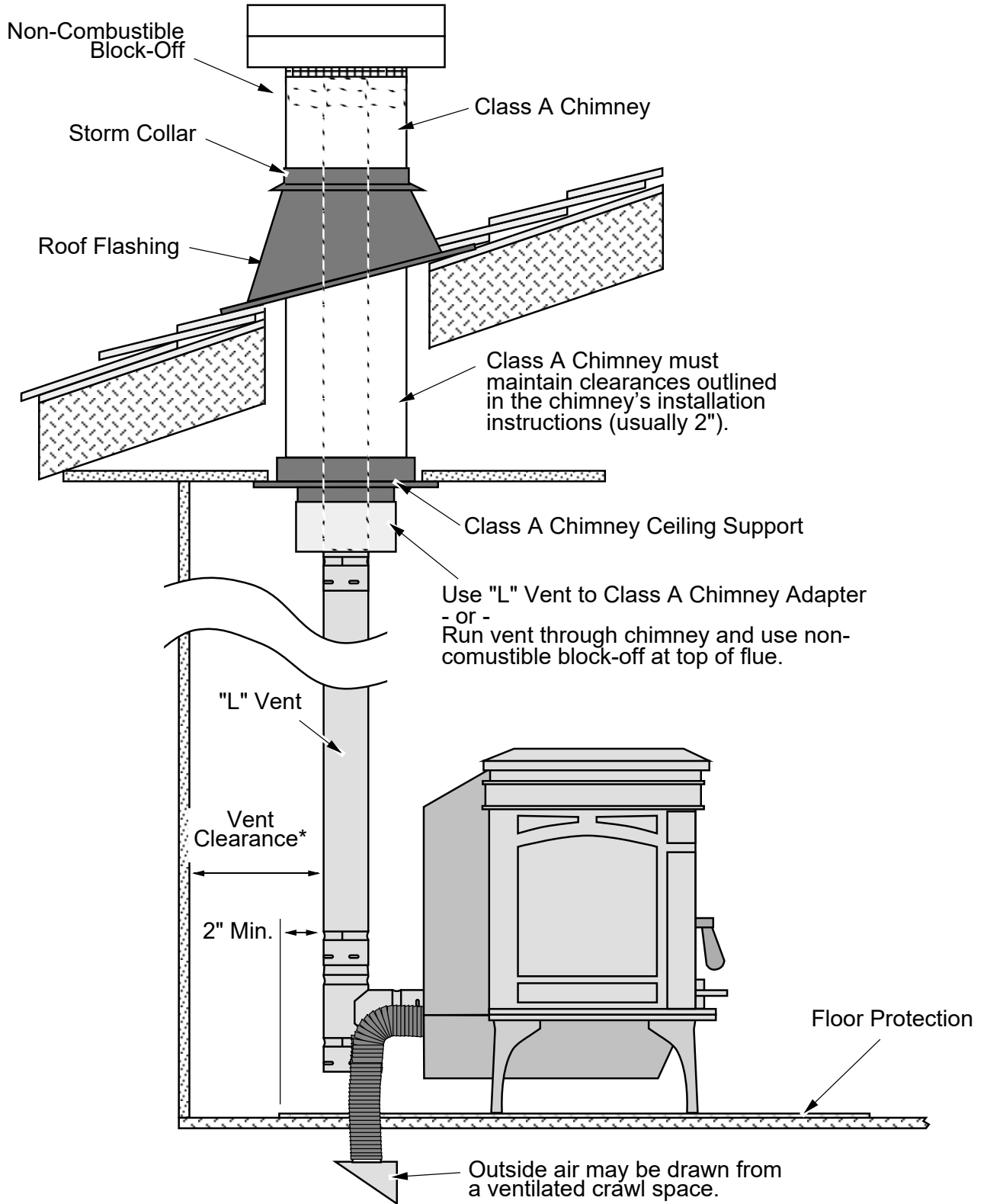

* Install vent at clearance specified by the vent manufacturer.

Installation Example: Masonry Fireplace Hearth Stove

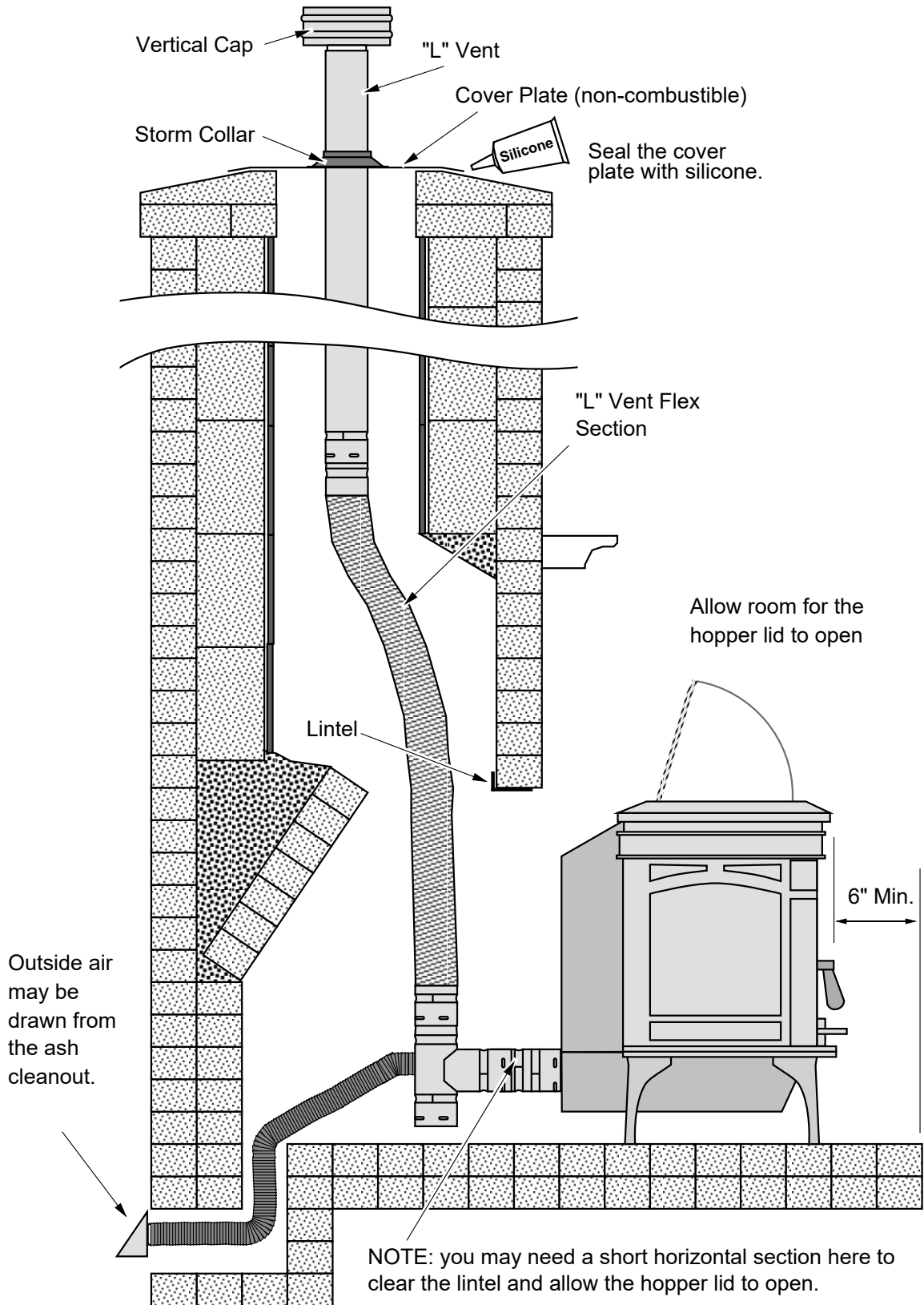

20 Installation (For Qualified Installers Only)

Installation Example: Zero-Clearance (Metal) Fireplace Hearth Stove

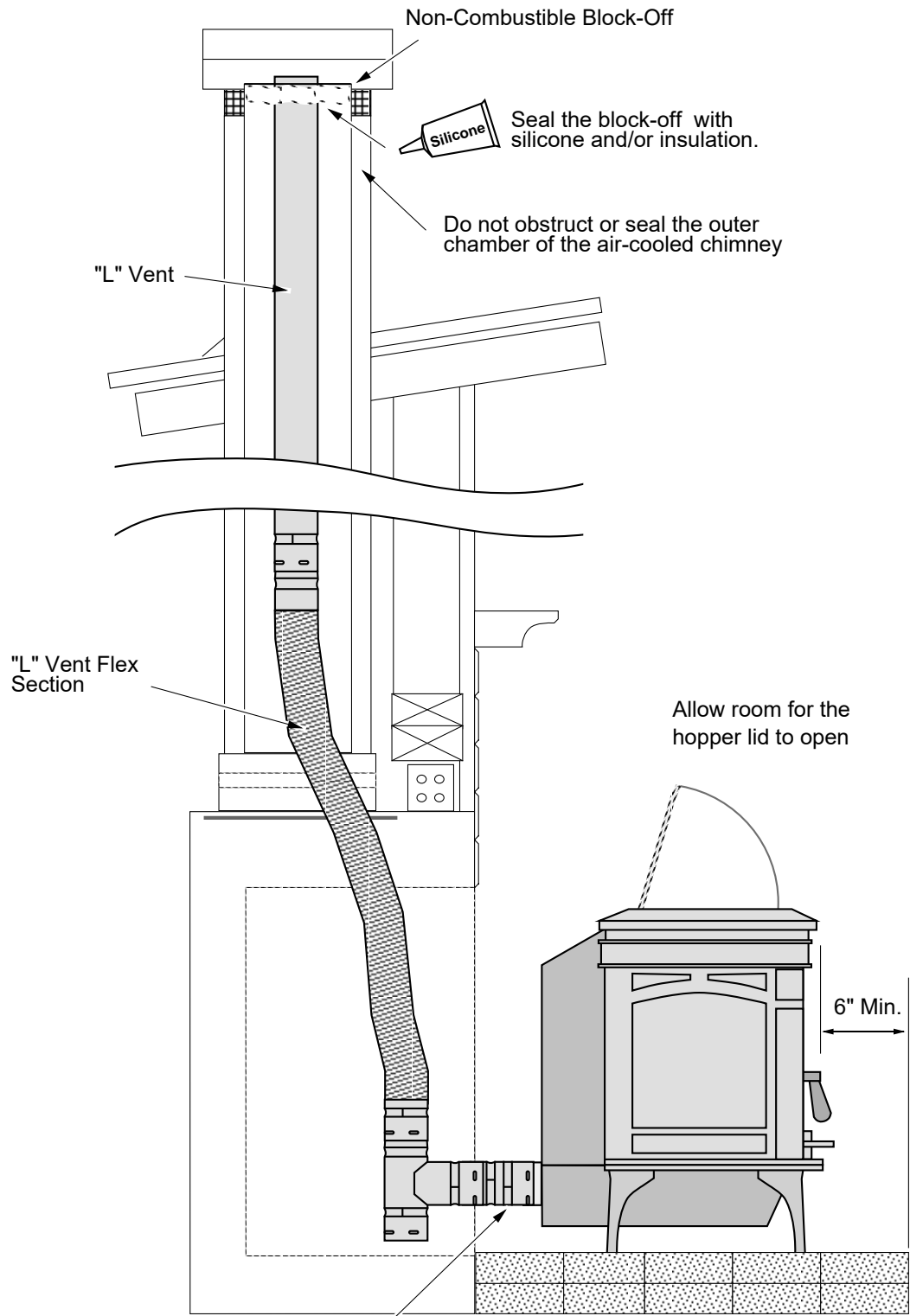

NOTE: you may need a short horizontal section here to clear the lintel and allow the hopper lid to open.

Installation Example: Freestanding Masonry Chimney

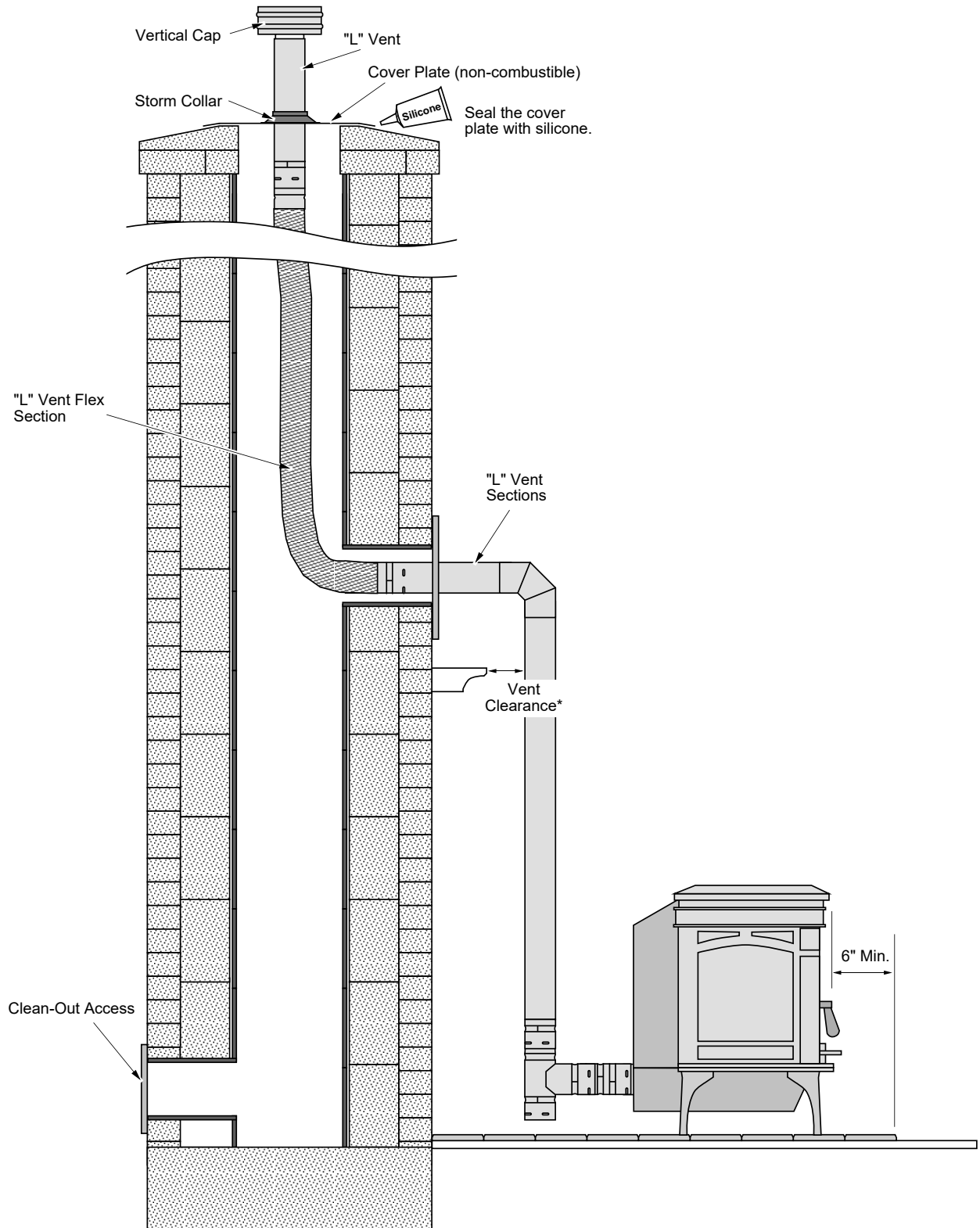

* Install vent at clearance specified by the vent manufacturer.

Safety Notice

READ THIS ENTIRE MANUAL (ESPECIALLY THE "SAFETY PRECAUTIONS" ON PAGES 4 AND 5) BEFORE USING THIS HEATER. FAILURE TO FOLLOW THE INSTRUCTIONS MAY RESULT IN PROPERTY DAMAGE, BODILY INJURY, OR EVEN DEATH.



DO NOT UNPLUG THE HEATER TO TURN IT OFF. THIS HEATER RELIES UPON ELECTRICITY TO PUSH THE FLUE GASES OUT THE PELLET VENT – UNPLUGGING IT MAY LEAD TO SMOKE ENTERING YOUR ROOM.



FAILURE TO MAINTAIN YOUR HEATER WILL LEAD TO A RESTRICTED COMBUSTION AIR SYSTEM, LEADING TO POOR PERFORMANCE AND IN SOME CASES, SMOKE SPILLAGE INTO THE ROOM. SEE THE "MAINTENANCE" SECTION FOR DETAILS.



DO NOT USE CHEMICALS OR FLAMMABLE FLUIDS TO START THIS HEATER.



DO NOT OVERFIRE THIS HEATER: Attempts to achieve heat output rates that exceed heater design specifications can result in a house fire or permanent damage to the heater.

Touch Screen Controls

The touch screen is located on the hopper lid.

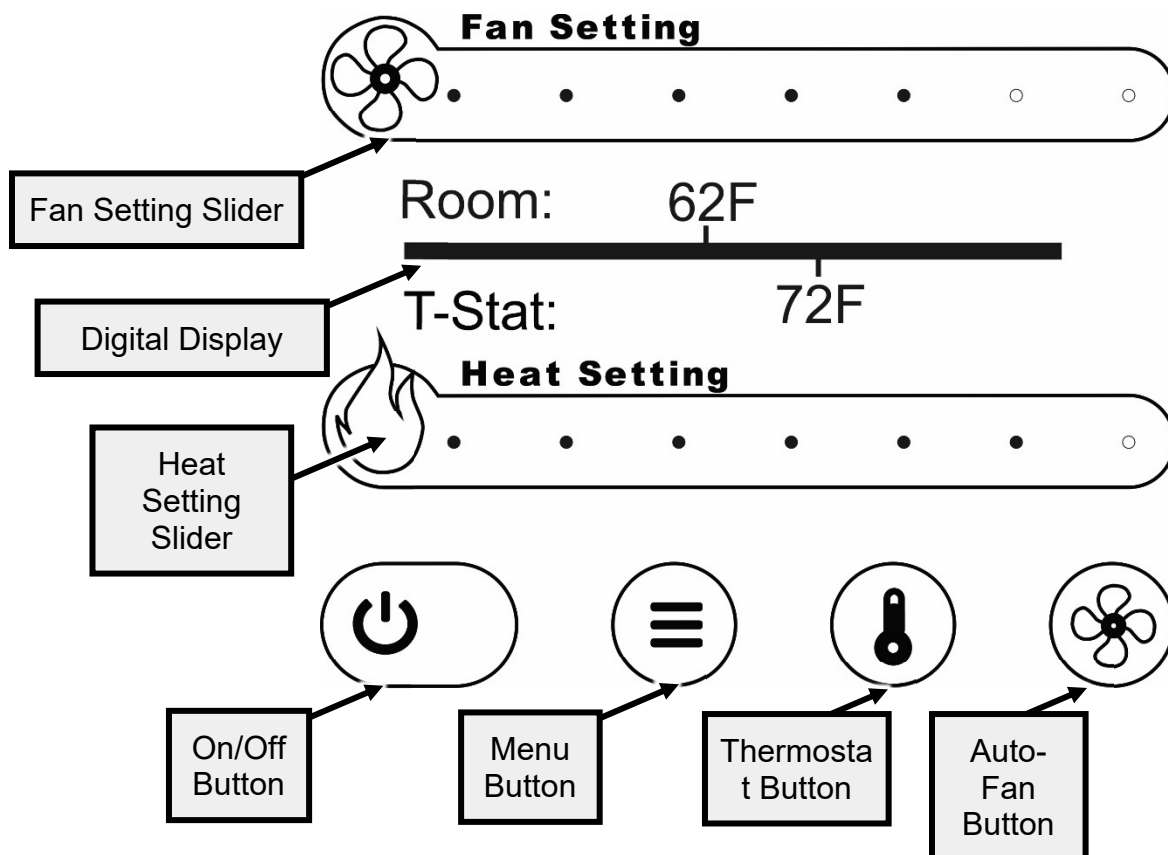

Loading Pellets

Lift the hopper lid to its vertical position. Pour pellets into the hopper.

NOTE: If the hopper lid is opened for more than 1 minute, the heater will enter a shutdown cycle. If this happens, simply restart the heater.

WARNING: The heater top becomes hot during operation. Make sure to keep any flammable items (bag of pellets) away from the top while reloading.

WARNING: The hopper lid is made of tempered glass. Do not slam or strike the lid.



Starting the Heater for the First Time

When you plug in the heater the first time the exhaust blower will run for approx. 15 minutes

This characteristic is a safety feature used to vacate smoke in case of a power outage.

Curing the Paint

This heater uses heat-activated paint that will emit some fumes while starting the first fire. Open doors and windows to the room to vent these fumes. You may also notice oil burning off of the interior of the heater. This rust-stopping agent will soon dissipate. Allow 48 hours for the paint to cure.

Allow 48 hours

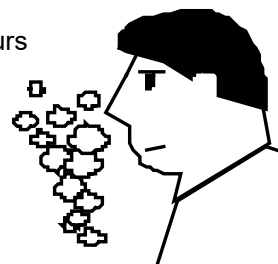
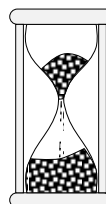

Burn the heater for approximately 1 hour on high - THEN OPEN AND CLOSE DOOR.

The door gasket contacts the painted surface on the front of the heater. To prevent the paint from bonding to the door gasket, you must burn the heater for approximately 1 hour, then open and close the door to break any bonding.

Simple Mode vs Advance Mode

When starting the stove for the first time, it will default to “Simple Mode”. To change to “Advanced Mode”, press the “Menu” button until you see “Advanced Mode”. Select “Advanced” by pressing on the lights below the Advanced option on the Heat Setting bar.

In Simple Mode, the stove defaults to thermostat operation. Select the temperature you would like the space to be, and the stove will control the heat setting to best achieve the desired temperature.

Advanced mode allows you to operate the stove in the same ways as Simple Mode, but it additionally allows you to manually control the heat output of the stove (non-thermostat operation).

NOTE: See the section “Advanced Mode - Operation” for an explanation of user-controlled options.

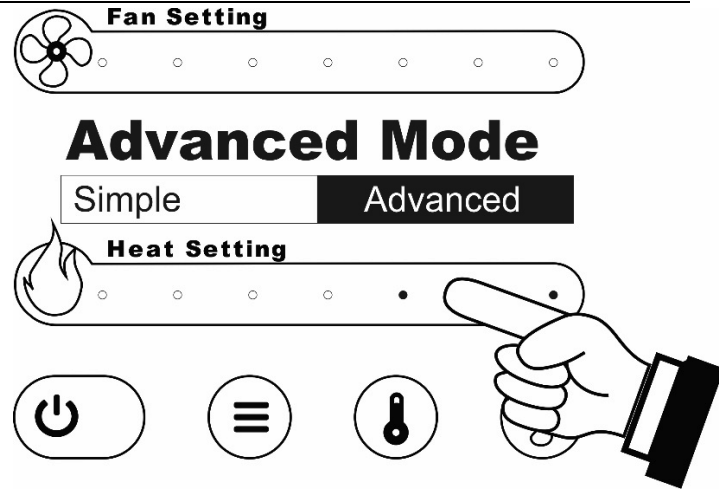

Simple Mode –Options

When using “Simple Mode”, there are three options that you can set to your preference.

- T-Stat Idle Mode
- Auto Fan or Manual Fan speed
- Heat Output (Pellet Feed Rate)
- Screen Lock

T-Stat Idle Mode

The stove allows you to select what it will do when the space reaches the temperature set on the thermostat. There are two choices.

- On & Off
- Low Burn

On & Off Option

The “On & Off” option allows the stove to turn itself off. When the room temperature drops below the stove thermostat temperature setting, the stove will begin another startup cycle and return to normal thermostat operation.

Low Burn Option

When the stove is set to the “Low Burn” option, it will turn itself down to its lowest setting when the heating need of the space has been met. The stove will continue to burn at that low rate until the thermostat calls for heat again. When heat is needed, the feed rate will return to the Heat Setting that is set on the “Heat Setting” slider, until the call for heat has been satisfied.

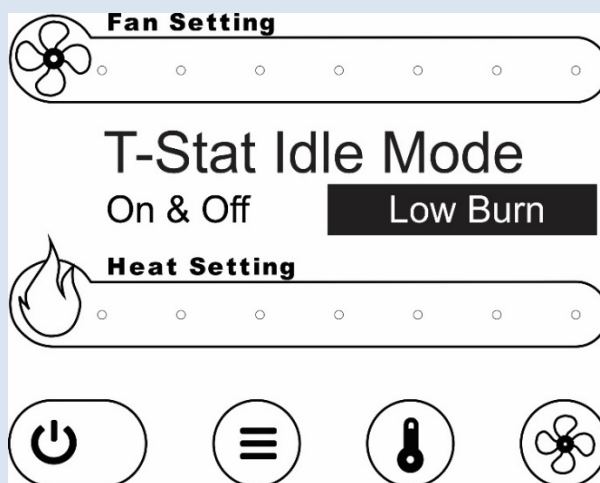

Auto-Fan

- This feature sets the fan speed to the same setting as the Heat Setting. If the heater is on high, the fan will be on high. If the heater is on low, the fan will be on low. When on, the Auto-Fan Button will display a blue LED light.



Heat Output

The heat output setting determines how quickly pellets will be pushed onto the burn platform and thus how big the fire is in the firebox. This can be used to help manage how often the stove has to light and shut down (also known as cycling). If the stove is cycling often, reduce the heat output.

Screen Lock

Use the Screen Lock feature to disable unwanted touch-screen input. This is typically done to prevent children or pets from inadvertently adjusting the heater.

Simple Mode - Operation

When heating is needed follow the steps below:

- Turn the stove on. The On/Off button is located in the lower left-hand corner of the display. Press the on/off Button to start and stop the heater.
- The On/Off Button will transition to GREEN.

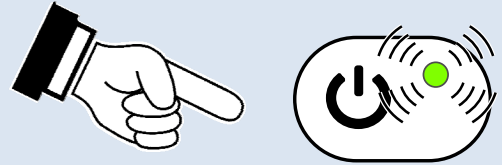

Setting the Target Temperature (simple mode only)

Internal (Built-In) Thermostat (available only when thermostat source is set to “Internal”).

NOTE: Internal or external thermostat is set by the installer in the “Dealer Service Mode”.

Press the Thermostat Button on the control panel. When the digital display shows the Heat Setting Slider, the target temperature is ready to be programmed. Use the Heat Setting Slider to adjust the target temperature.

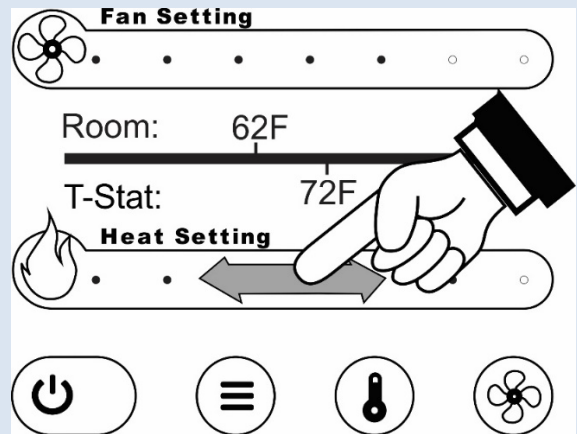
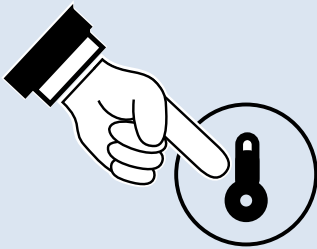

External Thermostat

External thermostats are available to control the pellet heater (wired, programmable, etc.). Refer to the instructions included with the external thermostat to set the target temperature.

NOTE: Internal or external thermostat is set by the installer in the “Dealer Service Mode”.

To Adjust the Heat Output

Use the Heat Setting slider to adjust heat output.

NOTE: Heat output may vary depending upon which TSTAT program you are in. For details see “Thermostat Programs” on page 32.

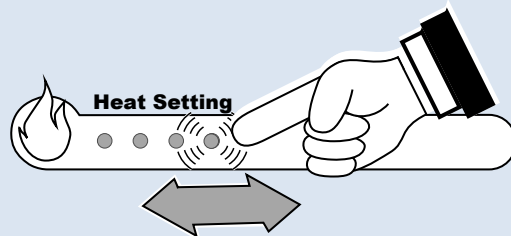

TIP: If the stove turns on and off repeatedly, you may wish to turn the heat output to a lower setting. This provides a more consistent heat output, eliminating the need for the thermostat to turn the heater on and off

- If the room temperature is lower than the thermostat setting on the stove, the stove will begin the start-up process, which can take approximately 20 minutes. During this time, the screen will display “Starting...” and will show the temperature that the thermostat is set to, as well as the room temperature (see right).

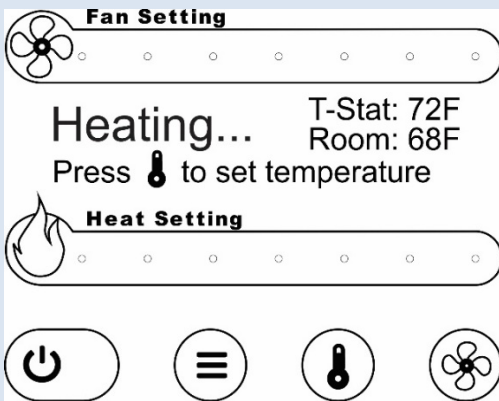
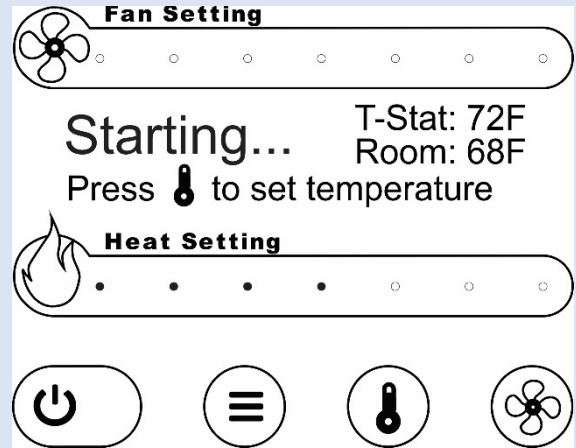

- After the stove has successfully ignited the readout will switch from “Starting...” to “Heating...”

- When the temperature of the room meets or exceeds the temperature setting on the stove, the stove will begin a shut-down process, which can take approximately 45 minutes. During this time, the screen will display “Cooling...” and will show the temperature that the thermostat is set to, as well as the room temperature (see right).

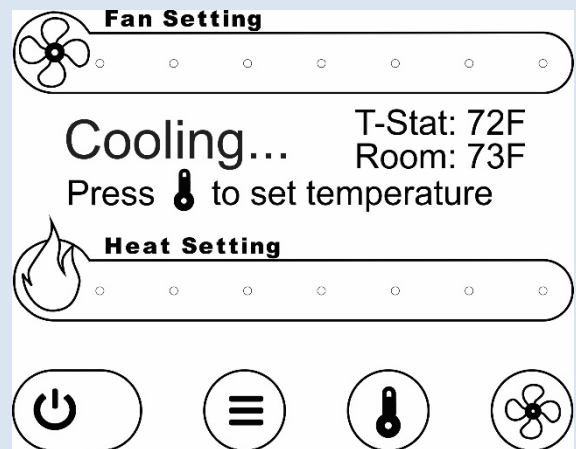

T-Stat Idle Mode

To set the T-Stat Idle Mode, press the menu button until you see the “T-Stat Idle Mode” on the display. Select one of the two options by touching the illuminated LED lights on the Heat Setting bar below your selection (see mode descriptions in the “Simple Mode –Options” section).

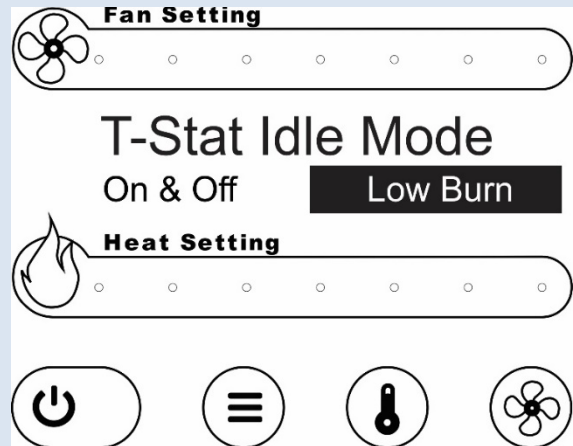

Fan Setting

There are two options for adjusting the room-air circulating fan.



The fan will turn on only after the heater is up to temperature (approximately 15 minutes after starting).

Manual Adjustments

Use the Fan Setting slider to set the fan speed.

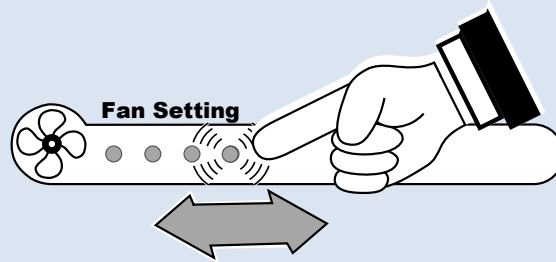

The fan remains on, even at its lowest setting. This is used to help cool the internal components and maximize heat transfer.

Auto-Fan

Press the Auto-Fan Button to activate the auto-fan feature. This feature sets the fan speed to the same setting as the Heat Setting. If the heater is on high, the fan will be on high. If the heater is on low, the fan will be on low. When on, the Auto-Fan Button will display a blue LED light.

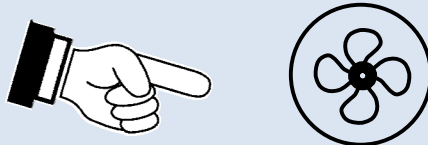

NOTE: the fan slider will “mirror” the heat slider when the heat slider is adjusted.

Screen Lock

Use the Screen Lock feature to disable unwanted touch-screen input. This is typically done to prevent children or pets from inadvertently adjusting the heater.

- TO LOCK THE STOVE,
Press the menu button until the Lock Stove menu appears. Select the “Locked” option then **WAIT 30 SECONDS FOR THE DISPLAY TO DIM.** The heater is now in locked mode.
- TO ADJUST SETTINGS IN LOCK MODE
Move your finger from left to right on the Heat Setting slider. Settings may then be adjusted.
- TO UNLOCK THE STOVE
Press the menu button until the Lock Stove menu appears. Select the “Unlocked” option.

Dealer Service Mode:

The stove has an area that is intended for dealers and service people. This area contains tools and settings to assist a trained professional in troubleshooting. This area is passcode protected to prevent accidental changes to these settings.

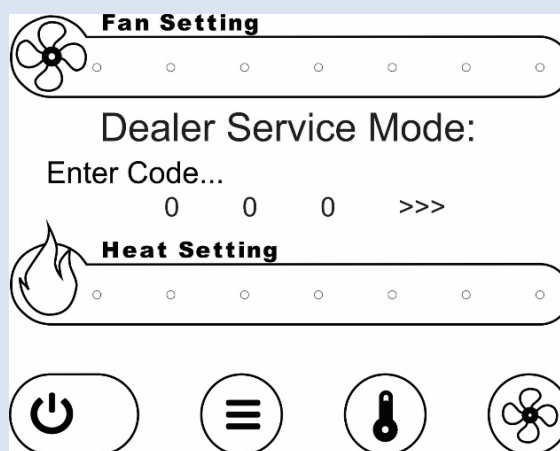

Advanced Mode –Options

When using “Simple Mode”, there are three options that you can set to your preference.

- Choice between T-Stat mode or Manual mode
- T-Stat Idle Mode
- Auto Fan
- Screen Lock

T-Stat or Manual Mode

When operating the stove in Advance Mode, you may choose to either have the stove function based on a thermostat (internal or external) or to run the stove in Manual. Manual allows you to set the heat output of the stove and stove will burn at that rate set until you either turn the stove off or the stove runs out of pellets.

T-Stat Idle Mode

The stove allows you to select what it will do when the space reaches the temperature set on the thermostat. There are two choices.

- On & Off
- Low Burn

On & Off Option

The “On & Off” option allows the stove to turn itself off. When the room temperature drops below the stove thermostat temperature setting, the stove will begin another startup cycle and return to normal thermostat operation.

Low Burn Option

When the stove is set to the “Low Burn” option, it will turn itself down to its lowest setting when the heating need of the space has been met. The stove will continue to burn at that low rate until the thermostat calls for heat again. When heat is needed, the feed rate will return to the Heat Setting that is set on the “Heat Setting” slider, until the call for heat has been satisfied.

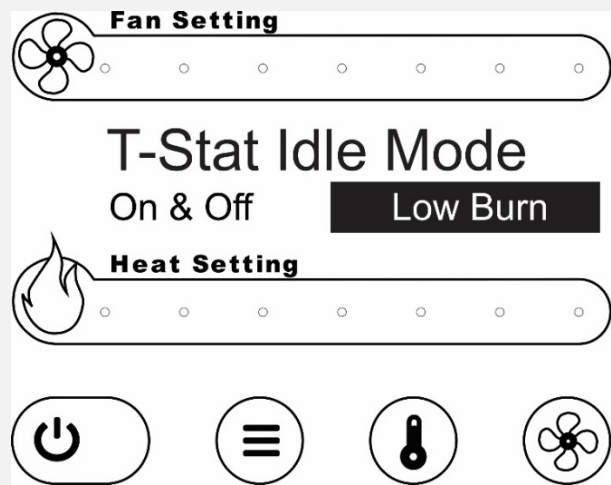

Auto-Fan

This feature sets the fan speed to the same setting as the Heat Setting. If the heater is on high, the fan will be on high. If the heater is on low, the fan will be on low. When on, the Auto-Fan Button will display a blue LED light.

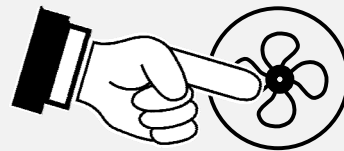

Heat Output

The heat output setting determines how quickly pellets are pushed onto the burn platform and thus how big the fire is in the firebox. This is used to help manage how often the stove has to light and shut down (also known as cycling). If the stove is cycling often, reduce the heat output.

Screen Lock

Use the Screen Lock feature to disable unwanted touch-screen input. This is typically done to prevent children or pets from inadvertently adjusting the heater.

Advance Mode - Operation

Manual or Thermostat

To switch between modes, press the Thermostat Button.

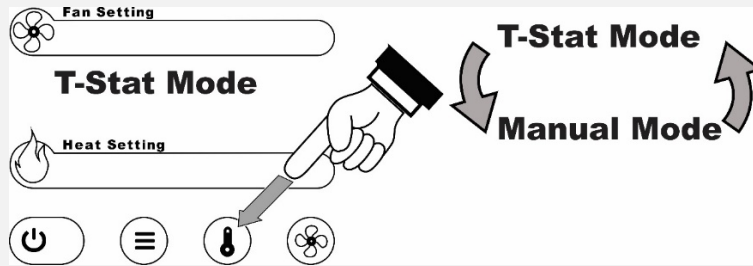

Manual Mode

Manual Mode requires the user to turn the heater on and off manually and select the heat output setting. When in Manual Mode the Thermostat Button will not be lit.



Thermostat Mode

Thermostat (T-Stat) Mode allows you to use a thermostat to control room temperature. When in Thermostat Mode the Thermostat Button will display a green light.



Manual Mode

Manual mode requires the user to turn the heater on and off manually and select the heat output setting.

To Start

Press the On/Off Button to start and stop the heater. The heater will begin the start-up process which can take approximately 20 minutes.

- The On/Off Button will transition to GREEN.

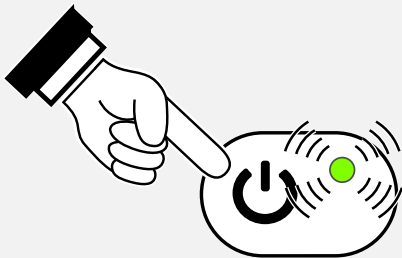

To Shut Down

Press the On/Off button on the control panel. The heater will begin the shut-down process, which takes approximately 45 minutes.

- The On/Off Button will transition to RED.

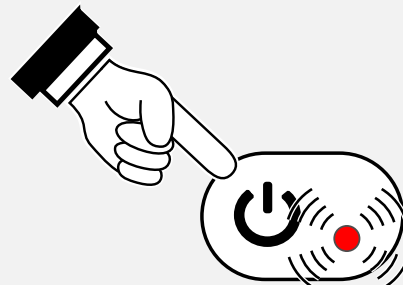

Manual Mode - Adjusting the Heat Setting

Use the Heat Setting slider to adjust the heat output.

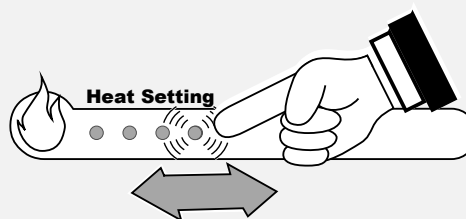

Thermostat (T-stat) Mode

Thermostat (T-stat) Mode allows you to use the internal (or external) thermostat to control room temperature. The heater automatically turns on when the temperature drops below the thermostat setting and turns off (or too low) once the thermostat setting is met.

Setting the Target Temperature

Internal (Built-In) Thermostat (Available only when thermostat source is set to “Internal” in the “Dealer Service Mode” menu)

Press the Menu Button on the control panel. When the digital display reads “Heat Setting” the target temperature is ready to be programmed. Use the Heat Setting Slider to adjust the target temperature.

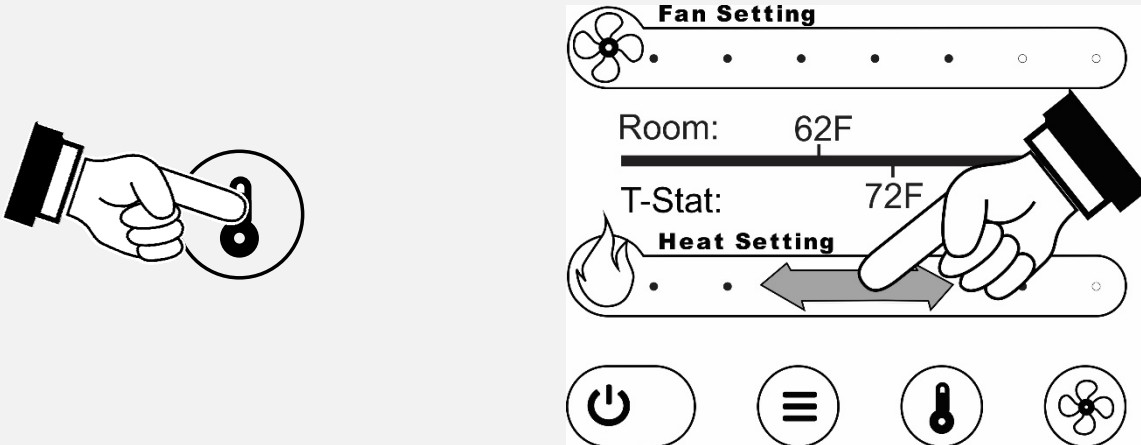

External Thermostat – (Must be selected by dealer in “Dealer Service Mode” menu)

NOTE: Several external thermostats are available to control the pellet heater (wired, wireless, programmable, etc....). Refer to the instructions included with the external thermostat to set the target temperature.

To Start the Stove in Thermostat Mode

Press the Thermostat Button on the touch screen. If there is a call for heat from the thermostat, the stove will enter the start-up sequence for approximately 20 minutes. When in Thermostat Mode the Thermostat Button will display a green light.



To Adjust the Heat Output

Use the Heat Setting slider to adjust heat output.

NOTE: Heat output may vary depending upon which TSTAT program you are in. For details see “Thermostat Programs” on page 32.

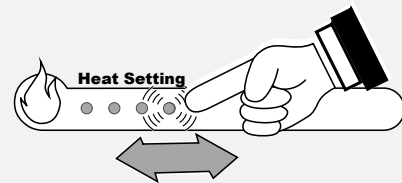

TIP: If the stove turns on and off repeatedly, you may wish to turn the heat output to a lower setting. This provides a more consistent heat output, eliminating the need for the thermostat to turn the heater on and off.

To Shut Down

Press the On/Off Button on the touch screen. The heater will begin the shut-down process, which takes approximately 45 minutes.

Thermostat Programs

This heater comes with two thermostat programs built-in. The programs allow you to modify how the stove responds to

when the thermostat setting is satisfied.

How to Get to the Thermostat Program Screen

- Press the Menu Button Until “T-stat Idle Mode” appears on the digital readout.

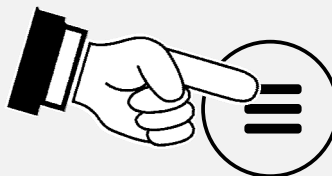

- Press the lights on the Heat Setting slider underneath the desired selection (On & Off or Low Burn).



On & Off Program

When the thermostat stops calling for heat (the thermostat is open) the following happens:

The burn rate decreases to Level 1 (lowest) for 15 minutes. If there is no call for heat during that time the heater turns off.

If there is a call for heat by the thermostat (the thermostat is closed) at any point during this cool-down period, then the burn rate resumes corresponding with the setting on the control panel.

Low Burn Program

In “Low Burn”, when the thermostat stops calling for heat (the thermostat is open) the following happens:

The burn rate decreases to Level 1 (low) and remains at this level until there is a call for heat by the thermostat (the thermostat is closed), then resumes corresponding with the setting on the control panel.

Fan Setting

There are two options for adjusting the room-air circulating fan.



The fan will turn on only after the heater is up to temperature (approximately 15 minutes after starting).

Manual Adjustments

Use the Fan Setting slider to set the fan speed.

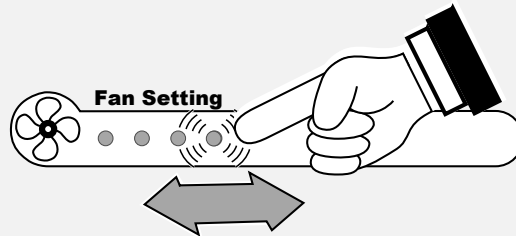

The fan remains on, even at its lowest setting. This is used to help cool the internal components and maximize heat transfer.

Auto-Fan

Press the Auto-Fan Button to activate the auto-fan feature. This feature sets the fan speed to the same setting as the Heat Setting. If the heater is on high, the fan will be on high. If the heater is on low, the fan will be on low. When on, the Auto-Fan Button will display a blue LED light.

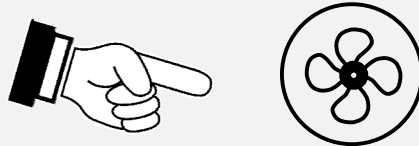

NOTE: the fan slider will “mirror” the heat slider when the heat slider is adjusted.

Heater Status

This heater has unique phases of operation (also called Heater Status). The descriptions below detail these phases to help the homeowner better understand how the pellet heater works.

Standby

The heater is plugged in, cool, and is not in operation.

Start-Up

Once the heater is started, it will go through a Start-Up phase. This phase turns the igniter on and feeds pellets to the burn platform. Once the Start-Up is complete the heater will enter the Heating phase.

Heating

The heater is on, pellets are being fed to the burn platform and are burning, the system detects heat, and the room fan is circulating air. When the heater is turned off (either manually, through a thermostat, or a fault occurred), the heater moves to the Cool-Down phase.

Cool-Down

The phase indicates the heater has recently been turned off. The heater will be warm, the pellets in the auger will be fed to the burn platform but new pellets are not being fed to the auger. This phase is necessary to ensure all remaining pellets are burned and flue products are expelled. Once the cool-down phase is complete, the heater will go to the Standby phase.

Heater Status - Continued

Idle

The heater is cooling down or off and waiting for a call for heat from the thermostat.

Fault

If the heater encounters a situation that is not normal, it goes into Fault status. The heater will go into cool-down and the fault encountered will be displayed. The most fault are as follows:

| Code | Description | What to Check |
|-----------------------------|--|--|
| “Overtemp Hopper (OT HOP)” | The hopper snap disc detected too much heat at the hopper. | <ul style="list-style-type: none"> • Hopper snap disk failure. • Convection fan not working. |
| “Overtemp HRD (OT HRD)” | The HRD snap disc detected too much heat at the HRD. | <ul style="list-style-type: none"> • HRD snap disk failure. • Stove overheating. |
| “Loss of Flame (POF)” | Proof of Flame not established. | <ul style="list-style-type: none"> • Potentially out of pellets. • Ignitor failure • POF snap disc failure |
| “Check for Auger Jam (ENC)” | Encoder signal Fault | <ul style="list-style-type: none"> • Check for Auger Jam. • Auger motor failure. |
| “Clean Burn Pot (POF)” | Proof of Fire never established upon ignition. | <ul style="list-style-type: none"> • Is the burn pot dirty? • POF snap disc failure |
| “Loss of Pressure (APS)” | Insufficient pressure detected at the pressure switch. | <ul style="list-style-type: none"> • Chimney needs to be cleaned. • Stove needs to be cleaned. • Plugged pressure hose. • Faulty pressure switch. • Exhaust fan failure |

Menu Button

The menu button allows access to the internal settings on the heater. To access, press the menu button (the screen below will be shown). Press the menu button again to scroll through the options listed below.

T-Stat Temperature (advanced mode only)

Use the Heat Setting slider on the touch screen to adjust the internal thermostat target temperature.

NOTE: If the T-Stat Source is set for external this setting will not appear.

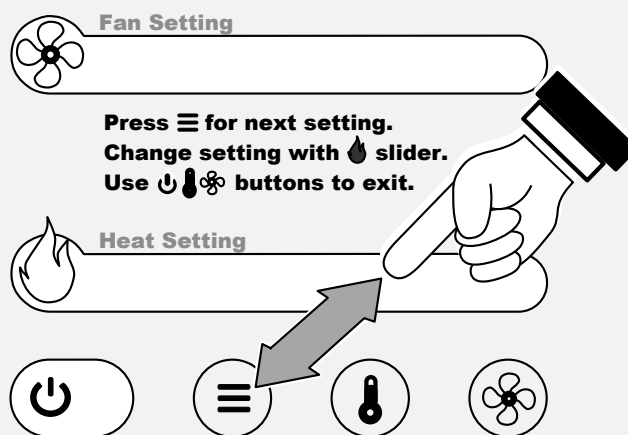

T-Stat Idle Mode

Use the Heat Setting slider on the touch screen to set the Thermostat Idle Mode (see page 25).

Screen Lock

Use the Screen Lock feature to disable unwanted touch-screen input. This is typically done to prevent children or pets from inadvertently adjusting the heater.

- **TO LOCK THE STOVE,**
Press the menu button until the Lock Stove menu appears. Select the “Locked” option then **WAIT 30 SECONDS FOR THE DISPLAY TO DIM.** The heater is now in locked mode.
- **TO ADJUST SETTINGS IN LOCK MODE**
Move your finger from left to right on the Heat Setting slider. Settings may then be adjusted.
- **TO UNLOCK THE STOVE**
Press the menu button until the Lock Stove menu appears. Select the “Unlocked” option.

Dealer Service Mode:

The stove has an area that is intended for dealers and service people. This area contains tools and settings to assist trained professionals in troubleshooting. This area is passcode protected to prevent accidental changes to these settings.

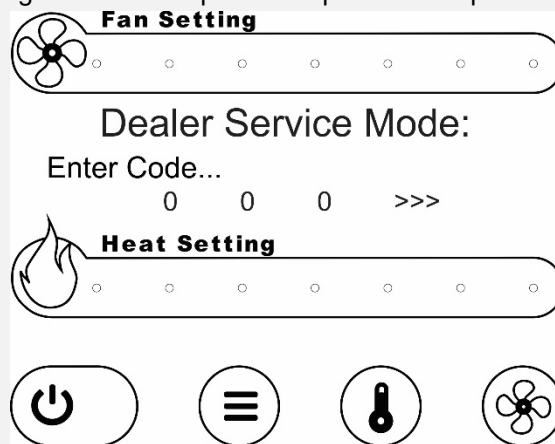

Menu Flow Chart

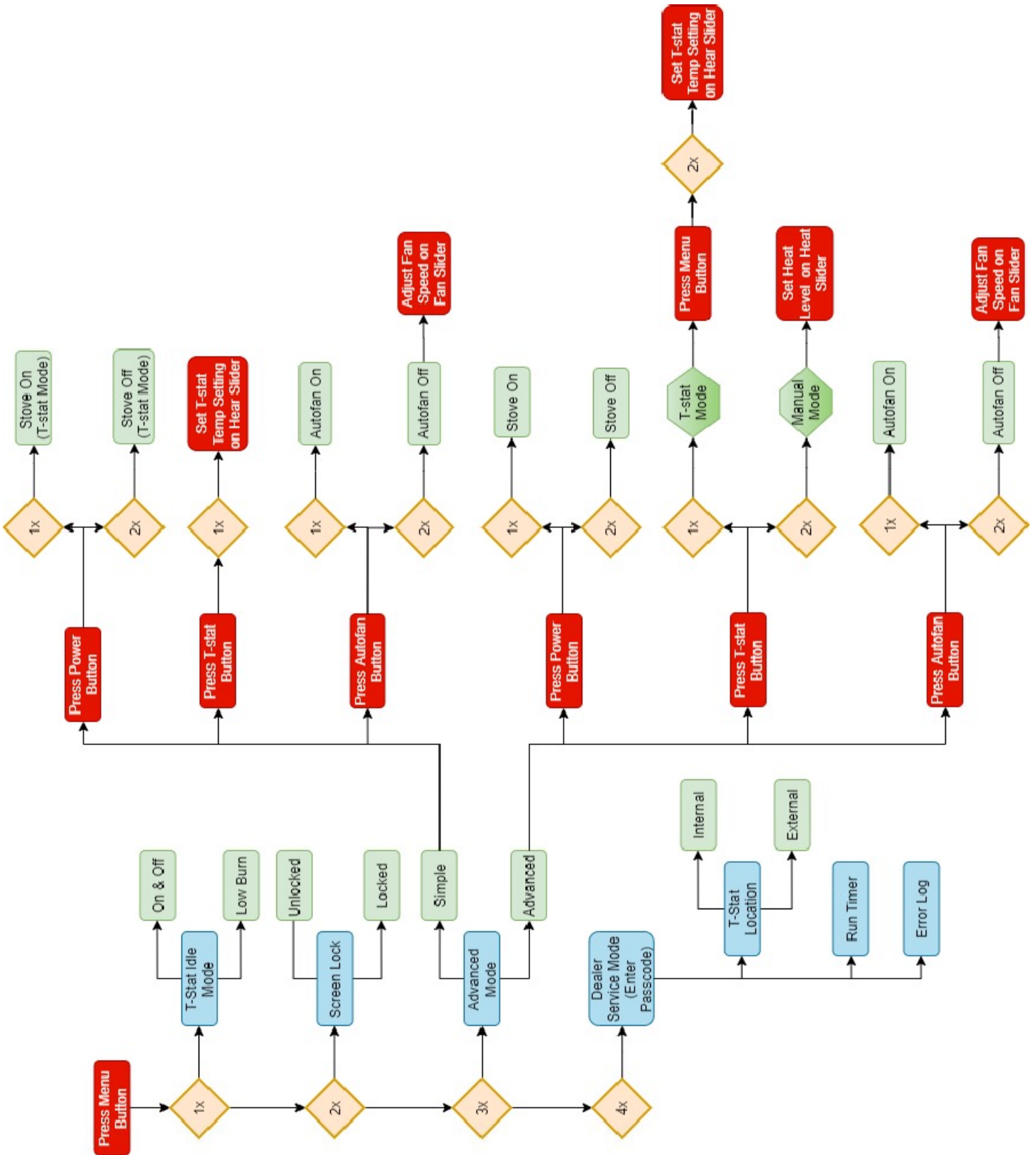

Power Outages



Because this stove relies upon a blower to evacuate smoke, some smoke may enter the home during a power outage. Leave the door closed to keep the possibility of smoke spillage to a minimum.

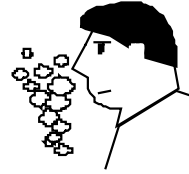
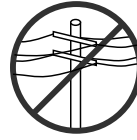

NOTE: Travis Industries recommends a minimum vertical vent of 5' to ensure adequate draft during a power outage.



After a power outage (or when plugging the heater in) the exhaust blower will run for approx. 15 minutes. This is a safety feature used to vacate smoke in case of a power outage.

Mode Defaults to "Simple Mode"

If a power outage occurs and power is restored the stove will default to "Simple Mode" and function based on the last known thermostat setting used in that mode. If the thermostat calls for heat, the heater will enter the start-up sequence and restart. If the thermostat does not call for heat it will enter a cool-down phase (exhaust blower will run up to 20 minutes to ensure smoke evacuation).

NOTE: If the thermostat has never been used in Simple Mode, the stove will default to 71°F.

Normal Operating Sounds



After a power outage (or when plugging the heater in) the exhaust blower will run for approx. 15 minutes. This is a safety feature used to vacate smoke in case of a power outage.

Creaks and Clicks

The steel may creak or click when the stove heats up and cools down - this is normal.

Exhaust Blower

This blower creates a low-pitched hum. This sound increases as the heat output is increased.

Chisel

The chisel separates the pellets in the hopper from the feed tube. Occasionally you may hear a "click" as a pellet is sheared.

Convection Blower

These blowers produce a slight hum and wind noise. This sound increases as the blower speed is increased.

Metering Auger Motor

You will hear this motor turning intermittently as it feeds pellets. You may also hear the pellets drop into the feed tube.

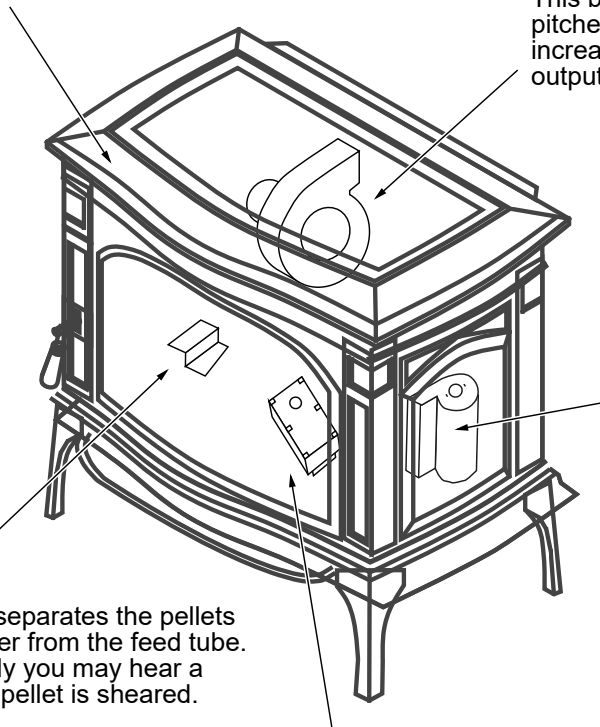

Stove Maintenance

The following section details extensive maintenance procedures. We strongly suggest these items be carried out by a trained service technician, possibly by a service agreement set up with your dealer.

NOTE: Pellet quality may vary by supplier. Your maintenance schedule may need to be revised to accommodate the pellets used.



DISCONNECT THE POWER CORD AND MAKE SURE THE HEATER HAS FULLY COOLED (APPROXIMATELY 45 MINUTES) PRIOR TO CONDUCTING SERVICE.

Maintenance Schedule

Weekly Maintenance (or every 5 bags of fuel):

- Inspect Burn
- Clean the burn platform
- Clean the heat exchanger

Monthly Maintenance (or every 20 bags of fuel):

- Empty the ashpan
- Clean the glass
- Inspect the door
- Clean firebox liners

Yearly Maintenance (or every ton of fuel):

- Check for air leaks
- Clean lower exhaust duct
- Clean convection blower
- Clean negative pressure tube
- Clean the vent
- Clean under burn platform
- Adjust door hinge and latch
- Check for air leaks

Removing Fly ash

This heater was designed to allow for easy fly ash removal with the included tools. However, to ease maintenance, some pellet stove owners have purchased vacuums specifically made to remove fly ash. Furthermore, some of these vacuums are heat-resistant to allow for fly ash removal while it is still warm. **DO NOT USE A STANDARD VACUUM ON THIS APPLIANCE** (except to clean the pellet dust out of the hopper). Standard vacuums may spread the fine particles inside the fly ash into the home and are not heat-resistant (hot fly ash may cause the internal portion of vacuums to ignite).

NOTE: Ask your authorized Travis dealer for a recommended ash vacuum.

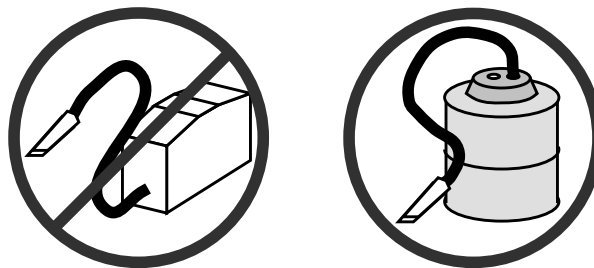

Disposal of Ashes

Ashes should be placed in a metal container with a tight-fitting lid. The closed container of ashes should be placed on a noncombustible floor or on the ground, well away from all combustible materials, pending final disposal. If the ashes are disposed of by burial in soil or otherwise locally dispersed, they should be retained in the closed container until all cinders have been thoroughly cooled.

Stove Maintenance Tools

Included with the stove are three tools for maintenance: a bottle brush, brush, and cleaning tool.



Opening the Door



MAKE SURE THE HEATER HAS FULLY COOLED (APPROXIMATELY 45 MINUTES) BEFORE OPENING THE DOOR AND CONDUCTING SERVICE.

Lift the handle and pull to open the door as shown below.



Weekly Maintenance (or Every 5 Bags of Pellets) - Inspect the Burn

Once a week you should inspect the flame quality inside your appliance. When burning on high, the flames should be bright orange. If the flames seem to be coming only from the sides, or are orange/black, turn the heater off and check for clinkers (ashes that solidify into a clump). The most likely causes of clinkers are:

- Restrictor needs adjustment (see "Restrictor Adjustment" in the Installation section of this manual)
NOTE: The optimum restrictor position will vary over time as soot builds up inside the exhaust system. See "Restrictor Adjustment" for details.
- Poor pellet quality
- The door or glass has an air leak
- The exhaust system requires cleaning

Weekly Maintenance (or Every 5 Bags of Pellets) - Clean the Burn Platform

Once a week you should clean and inspect the burn platform. The following steps outline this process.

1. Open the door.
2. Remove the visual deflector. Note how the deflector has hooks on each side that fit over pins to the side of the burn platform.

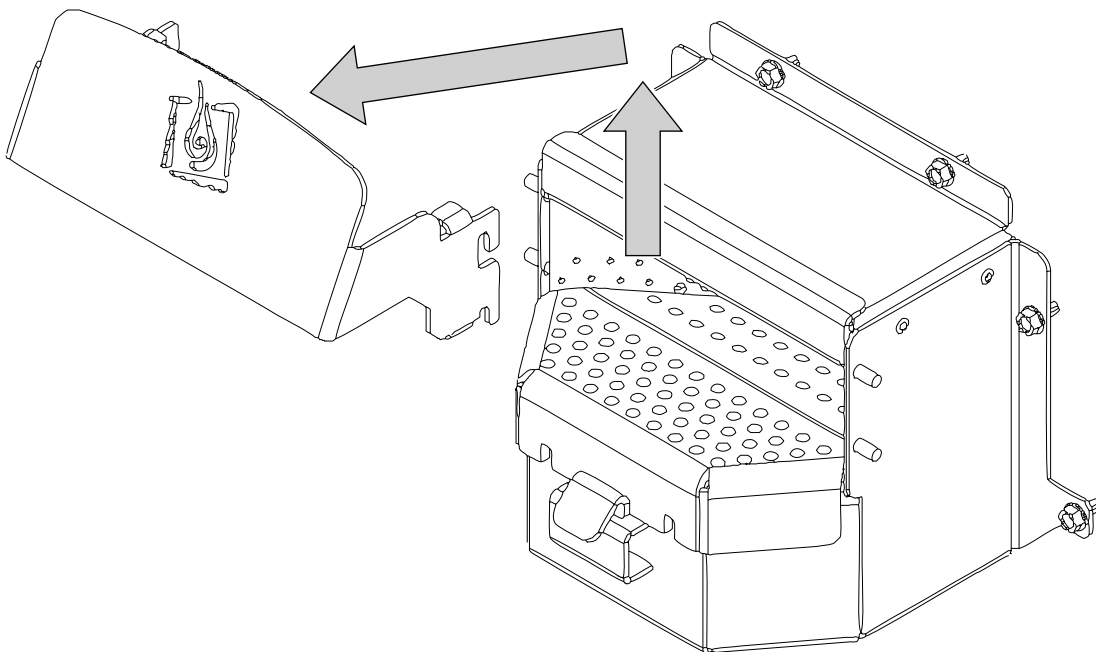

NOTES ON REPLACING THE VISUAL DEFLECTOR

When in place, make sure the visual deflector is pressed down fully on both sides. If it is not fully seated, airflow to the burn platform may be displaced and the appliance may burn poorly.

3. Use the cleaning tool to scrape away hardened clinkers or buildup on the burn platform. Use the narrow tip to clear any plugged holes. The burn platform must be free from buildup for the pellets to burn completely.



4. Brush away flyash around the burn platform using the brush included with the stove. The flyash will fall into the ashpan below.

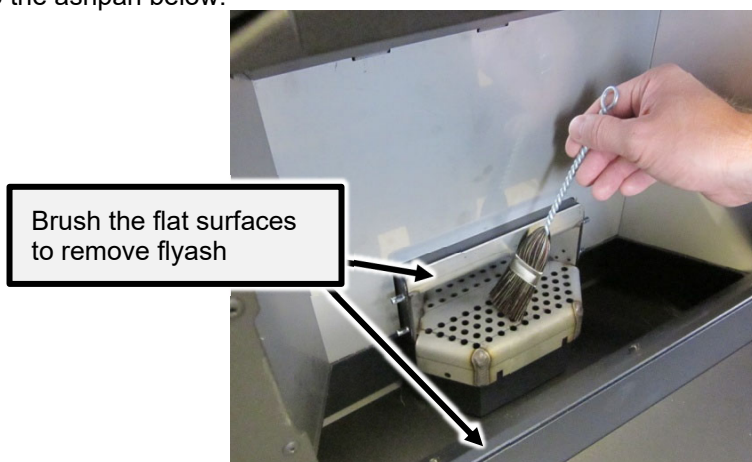

5. Remove the wedge that locks the burn platform in place. If the wedge is difficult to dislodge, use the cleaning tool to rock the wedge left to right.

NOTE: An extra wedge is included with the heater in case the original is misplaced.

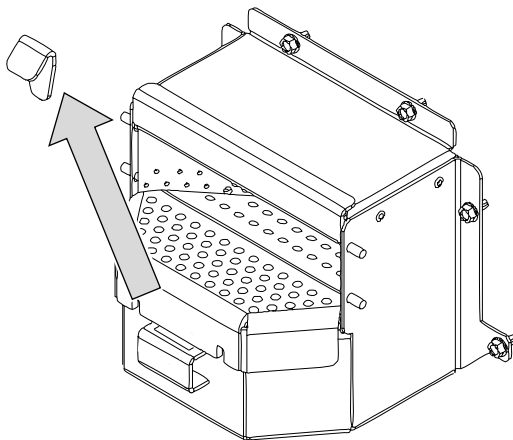

- 6 Remove the burn platform from the platform holder.

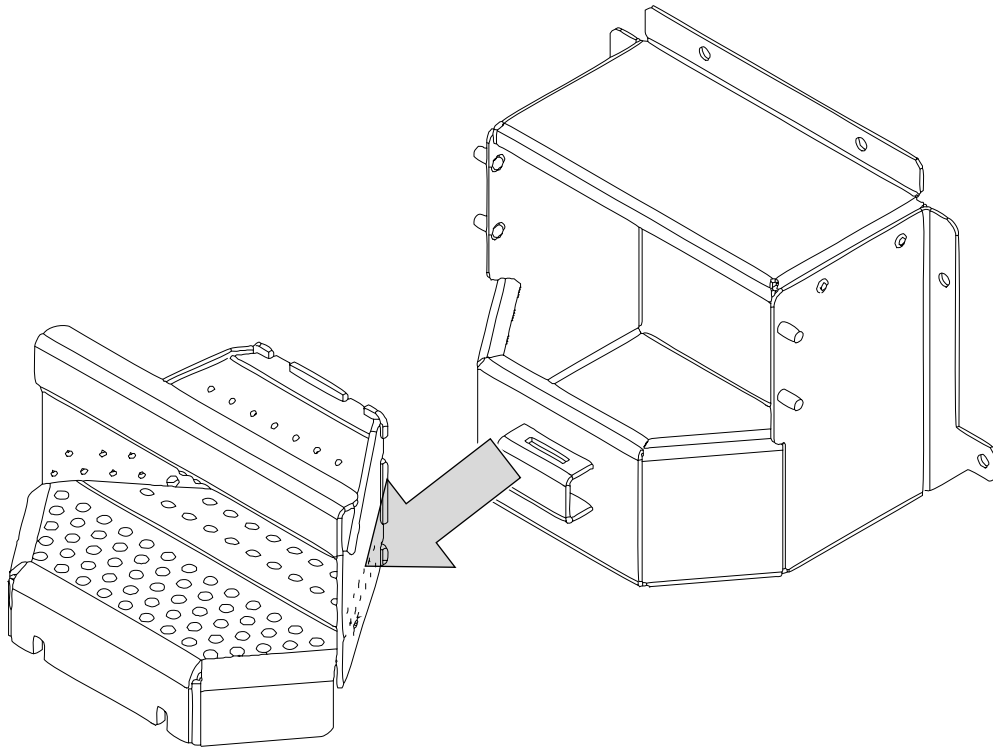

- 7 Clean the inside of the platform holder.



Cleaning Behind the Firebox Liners



Make sure the stove has fully cooled (approximately 45 minutes) before conducting service. Unplug the stove to prevent electrical shock.

1. Remove the visual deflector and burn platform (see section “Visual Deflector and Burn Platform Removal”).

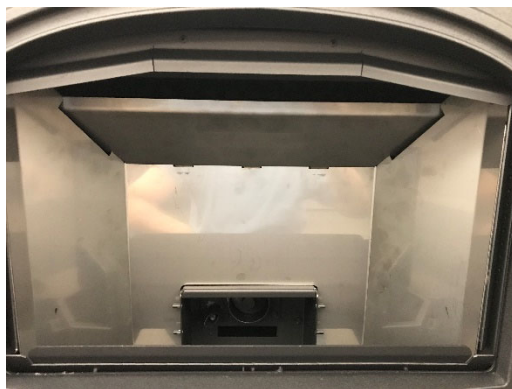

2. Lift the top center panel of the fireback to release it from the notches on the lower panels. Lower one side and guide the panel out of the firebox.

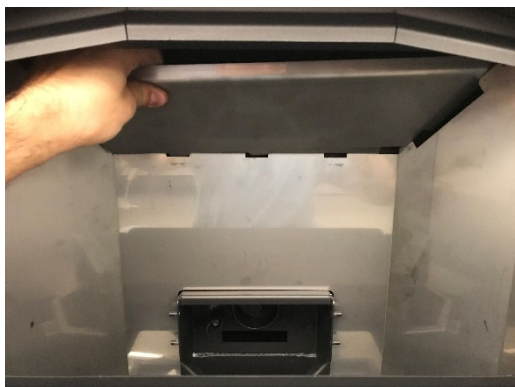

3. Lift up on one of the side panels to release the (2) tabs on the bottom of the panel from the notches in the firebox. Guide the bottom of the panel forward until it can be lowered into the ashpan area.

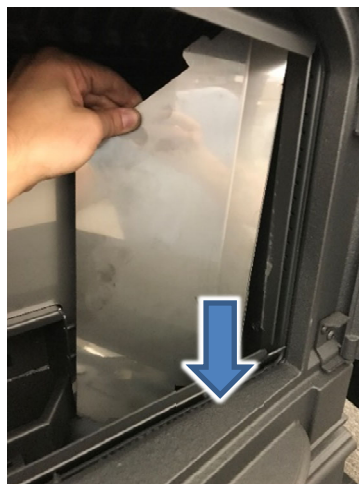
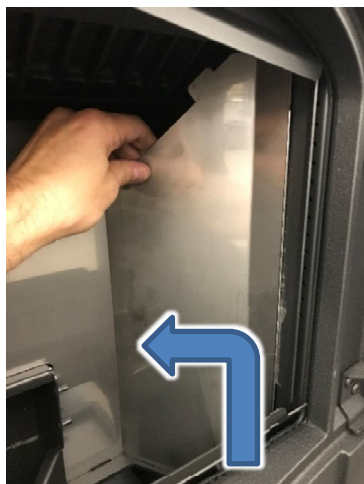

4. Tip the top edge of the side panel forward and guide the panel out of the firebox.



5. Repeat the same process for the other side fireback.
6. The rear fireback is between the back of the fireback and the mounting studs for the visual deflector. Lift the rear fireback straight up until the legs of the fireback can clear the mounting studs. Tilt it forward and guide it out of the firebox.



7. The back of the firebox is now visible



8. With the liners removed, clean all fly ash and debris from the firebox. Clean the liners before replacing them. Make sure to clean the heat exchanger on the firebox ceiling.



Monthly Maintenance (or Every 20 Bags of Pellets) - Clean the Glass

Open the doors and clean the glass with a non-abrasive glass cleaner and rag.

NOTE: do not allow glass cleaner (or other liquid) to soak into the gasket – this may compromise the gasket cement.

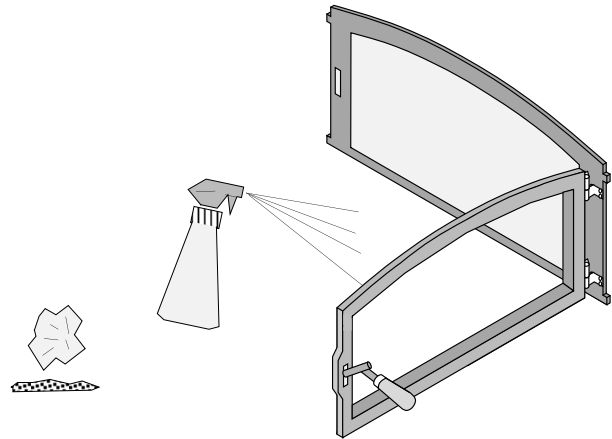

Monthly Maintenance (or Every 20 Bags of Pellets) – Empty the Ashpan



MAKE SURE THE HEATER HAS FULLY COOLED (APPROXIMATELY 45 MINUTES) BEFORE CONDUCTING SERVICE.



THE ASHPAN MUST BE IN PLACE WHILE THE HEATER IS IN USE.

The ashpan will accumulate ash as you use the appliance. See the steps below to empty the ashpan.

1. Rotate the ashpan handle clockwise and swing it down to access the ashpan.

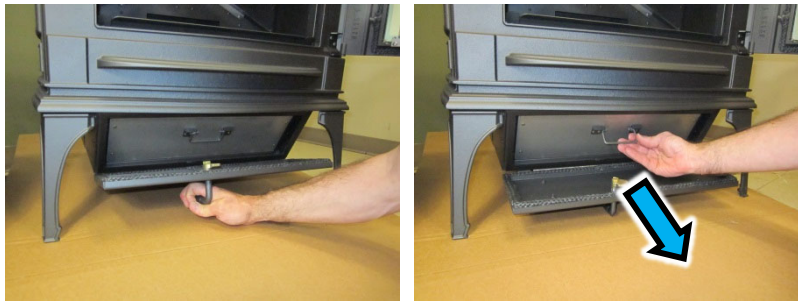

2. Slide the ashpan forward. Use the built-in handle to pull the ashpan out of the firebox.



3. Remove the ashpan from the appliance and properly dispose of the ashes (see “Disposal of Ashes” on page 39 for details). You may wish to clean the area below the firebox.

Monthly Maintenance (while appliance is in use)



Make sure the appliance has fully cooled prior to conducting service.

Door and Glass Inspection

The door must form an air-tight seal to the firebox for the stove to work correctly. Inspect the door gasket to make sure it forms an air-tight seal to the firebox.

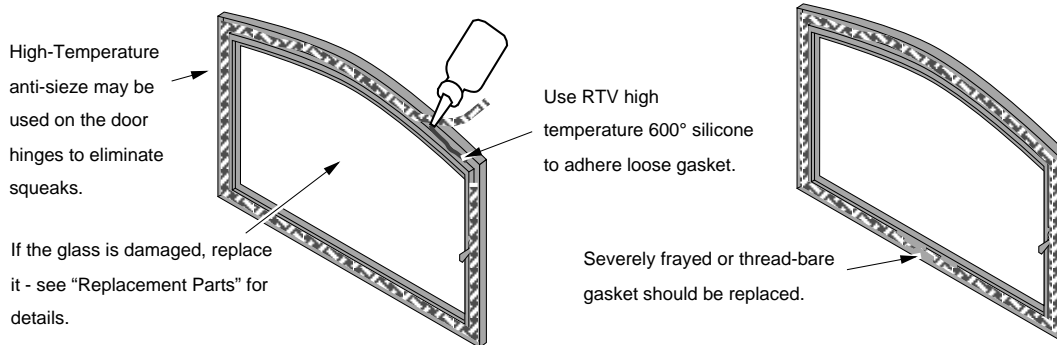

The door latch should pull the door against the face of the stove (but not so tight as to not allow full handle rotation). If the latch requires adjustment, follow the directions below.

Door Adjustment

The door latch should hold the door tightly against the stove while allowing the handle to rotate fully. If the latch requires adjusting, follow the directions below.

Loosen the bottom nut with a 7/16" wrench (see arrow to the right). Tap the bottom nut inwards, moving the door catch inwards. Tighten the nut and test operation. You may need to repeat this process, either moving the nut inwards or outwards, until the door catch is in the correct position.

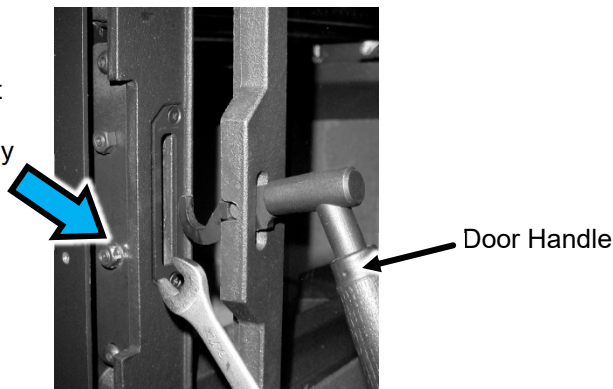

Yearly Maintenance (or Every Ton of Pellets) - Check for Air Leaks Around the Door, Glass, and Ashpan



Air leaks into the firebox will decrease the stove's performance greatly, leading to excessive sooting, inefficient burning, and perhaps a malfunction.

- Inspect the door gasket to make sure it is fully attached. If the door gasket is worn or flattened, replace it.
- If the glass is cracked, replace it. The glass is held in place with clips.
- Open the ashpan access door and inspect the gasket around the door. Re-attach or replace the gasket if necessary.

NOTE: Ask your authorized Travis dealer to demonstrate how to check a door seal.

Yearly Maintenance (or Every Ton of Pellets) - Clean the Lower Exhaust Duct

1. Remove the exhaust duct cover as shown below. First, remove the wingnut from the left side of the exhaust channel cover. Pull the left side of the plate forward and slide the plate out of the unit.

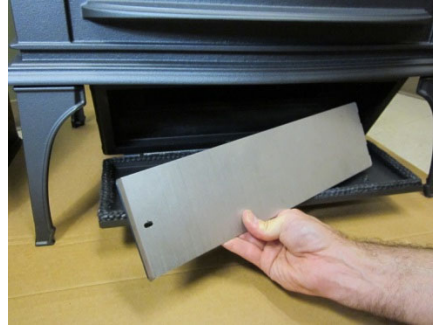

2. Clean the exhaust channel with the bottle brush or vacuum.

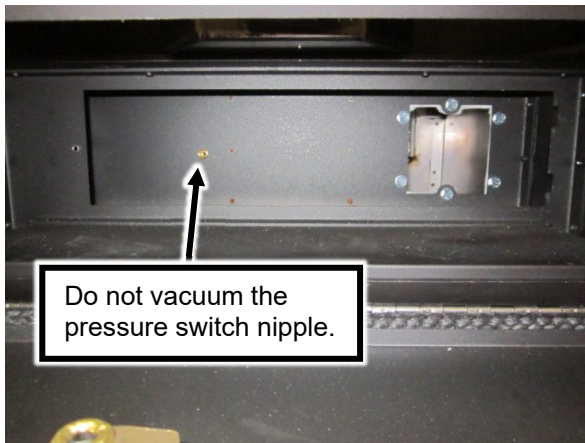

- Remove the access plate on the exhaust blower housing by removing the (6) ¼" hex head screws. Remove the plate and gasket and keep these parts for reinstallation. If the gasket material is deteriorated or damaged replace it when reinstalling the cover plate. Clean the combustion blower with the bottle brush or vacuum.

NOTE: Take care to prevent damaging the combustion blower impellers.

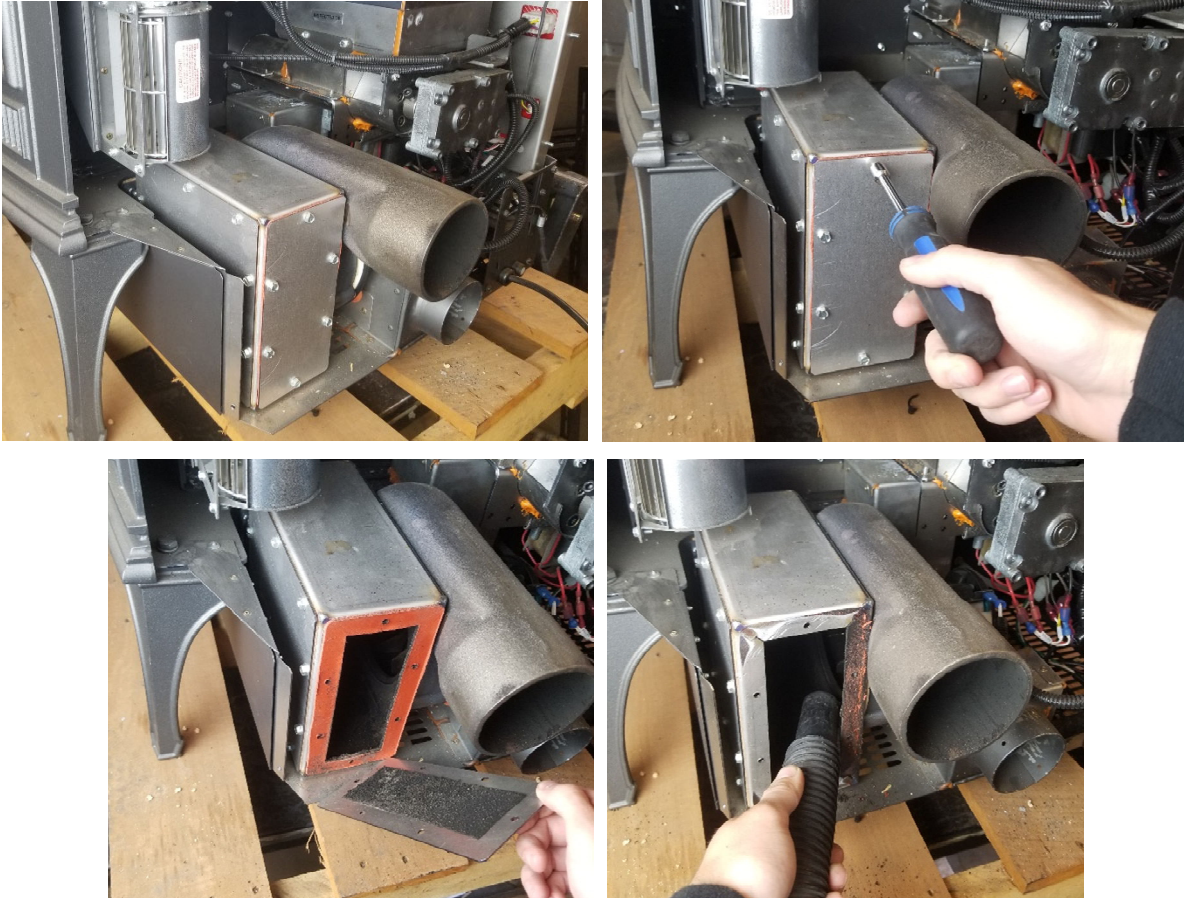

Yearly Maintenance (or Every Ton of Pellets) - Clean the Convection Blowers

- There are two convection blowers on this appliance, one on each side. The rear panel must be removed to access the blowers. Remove the (3) 5/16" screws along the top and (3) additional screws along the bottom of the rear panel. Lift up on the panel using the handle on the top edge to disengage the bottom of the panel from the floor of the stove.

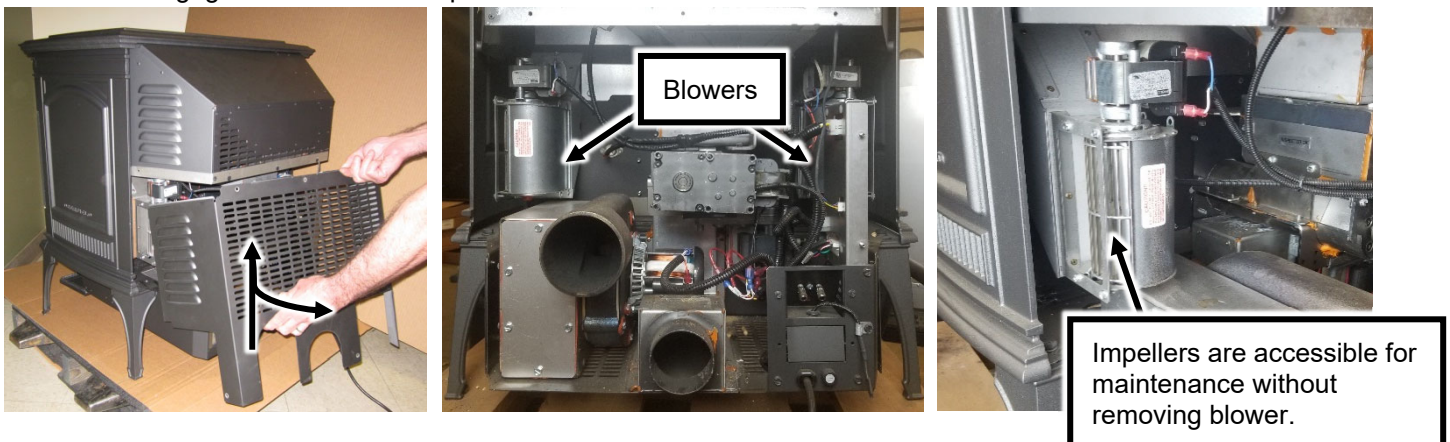

2. The impellers for each blower are accessible without removing the blower from the unit. Use a brush and vacuum to gently remove any buildup.

NOTE: Take care to prevent damaging the blower impellers while performing this maintenance. If an impeller becomes unbalanced, it will cause the blower to be noisy during use.

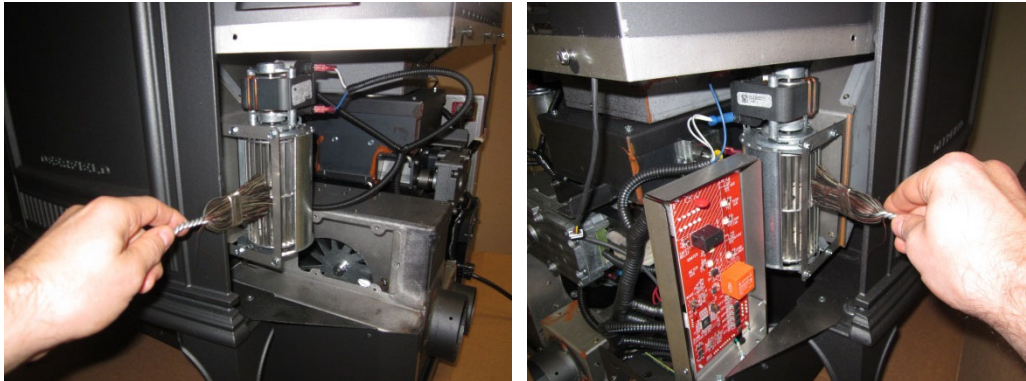

Yearly Maintenance (or Every Ton of Pellets) - Clean the Negative Pressure Tube

1. The negative pressure tube connects the Negative Pressure switch to the exhaust plenum. It is located below the left-hand convection blower. Disconnect the end of the tube from the switch and blow compressed air through the tube. Reinstall the tube onto the switch.

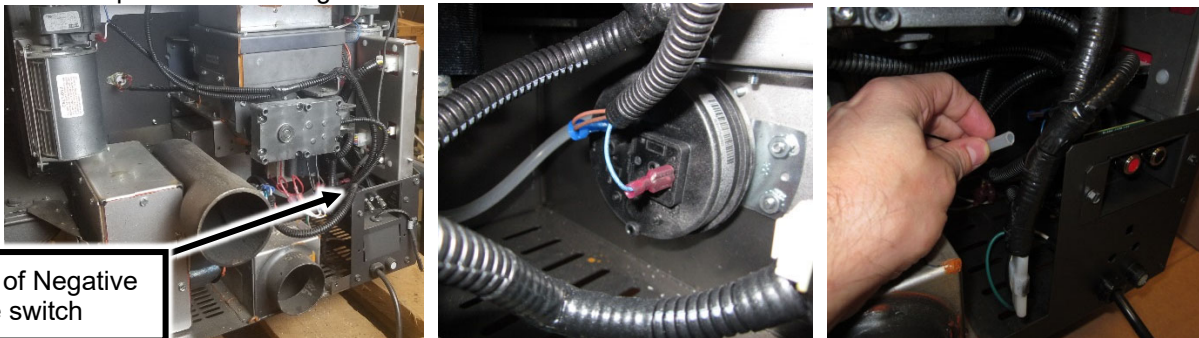

Location of Negative Pressure switch

2. Remove the ash pan and the exhaust cover plate. Locate the pressure switch nipple and make sure there is no debris in the opening (use a brush to clean – do not use a vacuum cleaner). Return the stove to its proper configuration.



Pressure Switch Nipple

Exhaust outlet

Yearly Maintenance (or Every Ton of Pellets) - Clean the Vent

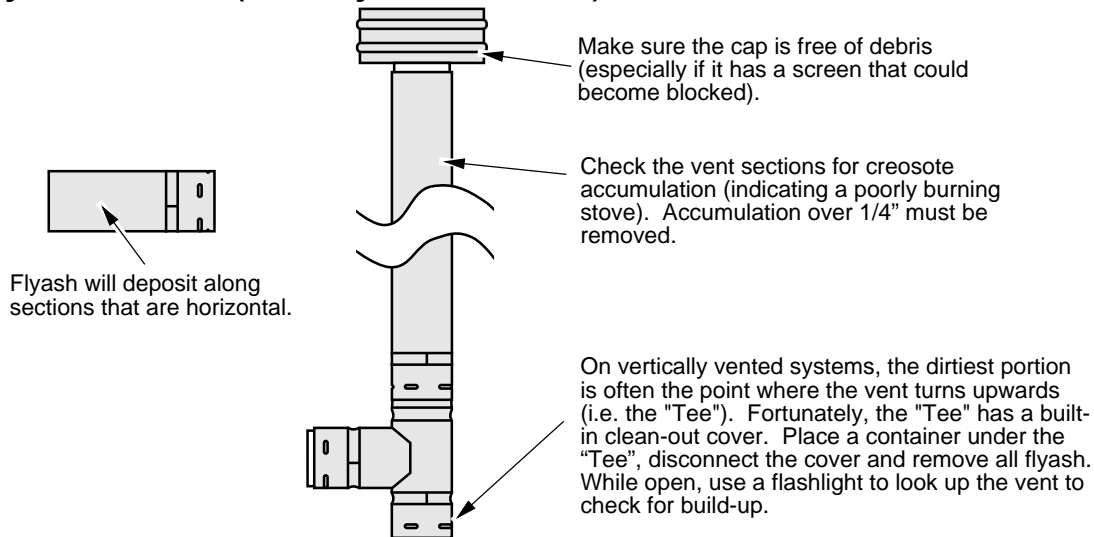

WHENEVER ANY PORTION OF THE PELLET VENT IS DISCONNECTED, THE JOINTS MUST BE SEALED WITH RTV 500° F. SILICONE SEALANT, UNLESS OTHERWISE SPECIFIED BY THE VENT MANUFACTURER.

Every Two Years (or Every 4 to 6 Tons of Pellets) Chisel Replacement

- The chisel is designed to shear pellets during operation. As the chisel becomes dull over time it will make it harder for the appliance to shear pellets and could shorten the life of the feed motor. We recommend that the chisel be replaced every two years or 4 to 6 tons of pellets to help ensure proper operation of the appliance.
- To remove the chisel, first, remove all pellets from the hopper. Turn the appliance on and turn the heat rate to "HIGH". The hopper lid switch will need to be held in the closed position (AGP appliances) or the hopper lid will need to be closed and you can look through the glass lid (Deerfield & Foxfire stoves) for the feed system to turn. The chisel will rotate into view (it is the serrated component held in place with two screws). Once the chisel is in the proper position, unplug the heater and remove the cover plate at the bottom of the hopper (6 screws hold it in place). The chisel is held in place with two cap head screws (use a 1/8" hex wrench to remove). Remove the chisel and replace it with a new chisel (available from your dealer). **NOTE: There is a shim (2 shims on older units) under the chisel – make sure to replace the shim when installing the chisel.** When replacing the cover plate, make sure to place the gasket between the cover plate and the hopper (use silicone if gasket is not used). This prevents pellet dust from falling below. Return the heater to the correct configuration before operating.

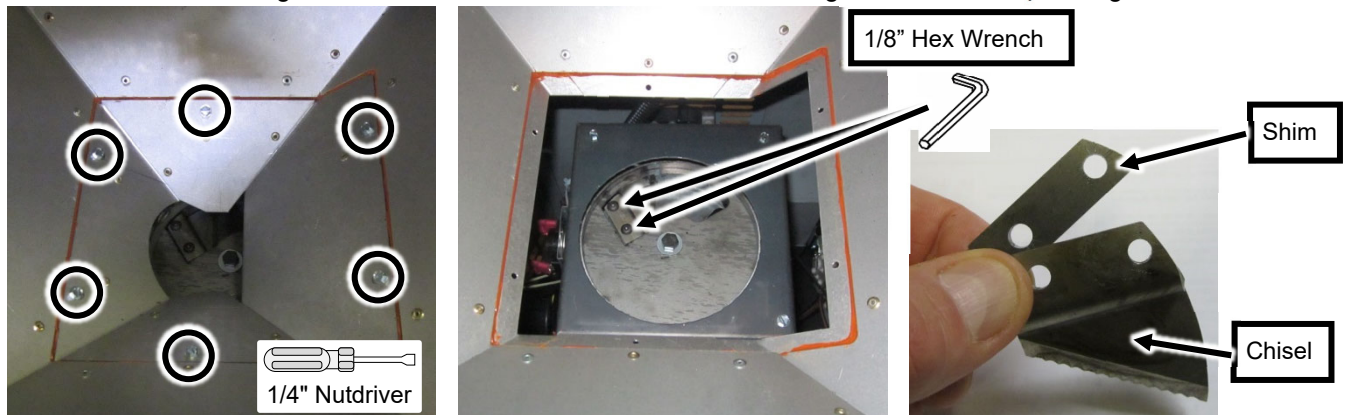

Door Parts

Contract your Travis Industries Dealer for replacement parts. Use only replacement parts from Travis Industries designed specifically for this heater.

Door Parts

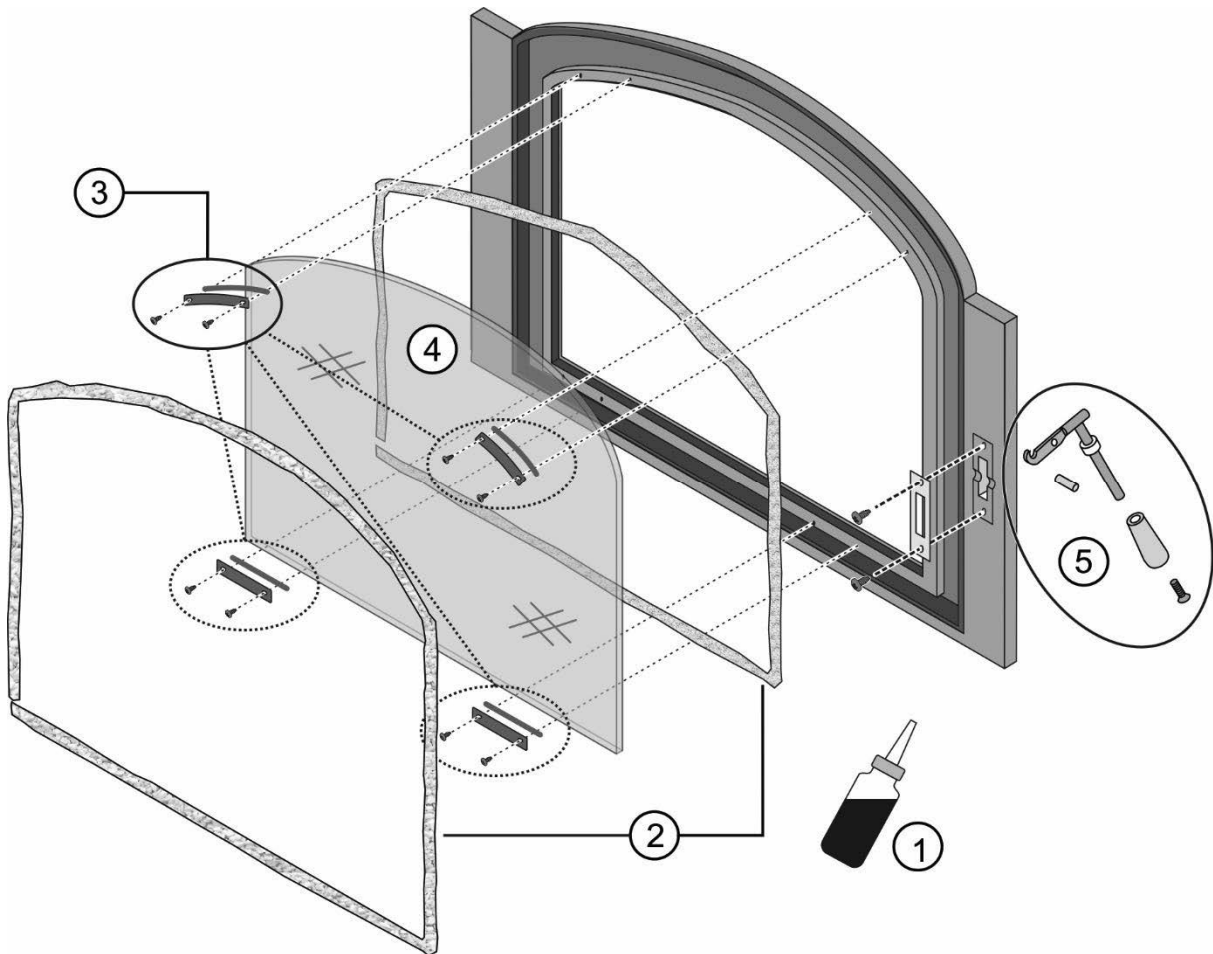

| ID # | Description | Qty. | Part # |
|------|---------------------------------|------|-----------|
| 1 | Gasket Cement with Brush | 1 | 250-04477 |
| 2 | Door and Glass Gasket Kit | 1 | 250-04665 |
| 3 | Glass Clip Set (2) Top/ (2) Btm | 1 | 250-03515 |

| ID # | Description | Qty. | Part # |
|------|-------------------|------|-----------|
| 4 | Glass | 1 | 250-04445 |
| 5 | Door Handle Assy. | 1 | 250-02196 |

Replacing the Glass



The glass must not contact the door retainer or glass clips directly. The glass gasket and glass clip gaskets insulate the glass to prevent cracking. Do not over-tighten the glass clips. Do not use substitute materials.

Replacing the Door Gasket

The door gasket inserts into the outer groove of the door and is held in place with RTV high-temperature silicone. Before installing, remove any residual cement. Lay the gasket in place (start at the lower right corner) and cut off any excess gasket.

NOTE: Do not stretch the gasket. You may need to open and close the door repeatedly to get the gasket to seat fully.

Replacing the Door Handle

See the illustration above for a component list (see page 48 for details on adjusting the door).

Removing the Door

To remove the door, open the door, then remove the four hex screws securing the hinges and remove the door and hinges as one assembly (see page 48 for details on removing the door).

NOTE: It will be helpful to have another person hold the door in place while removing the screws.

To remove the door, open the door, then remove the four hex screws securing the hinges and remove the door and hinges as one assembly.

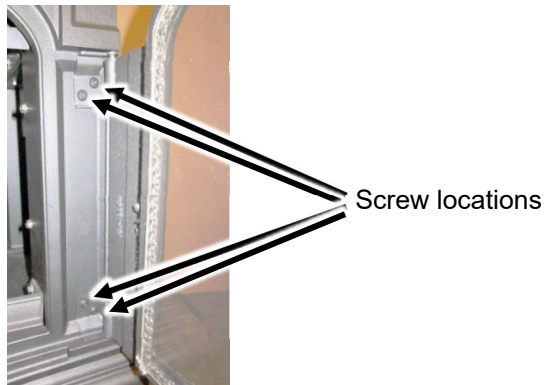

Wiring Diagram

FOXFIRE / DEERFIELD WIRING

POWER BRANCH

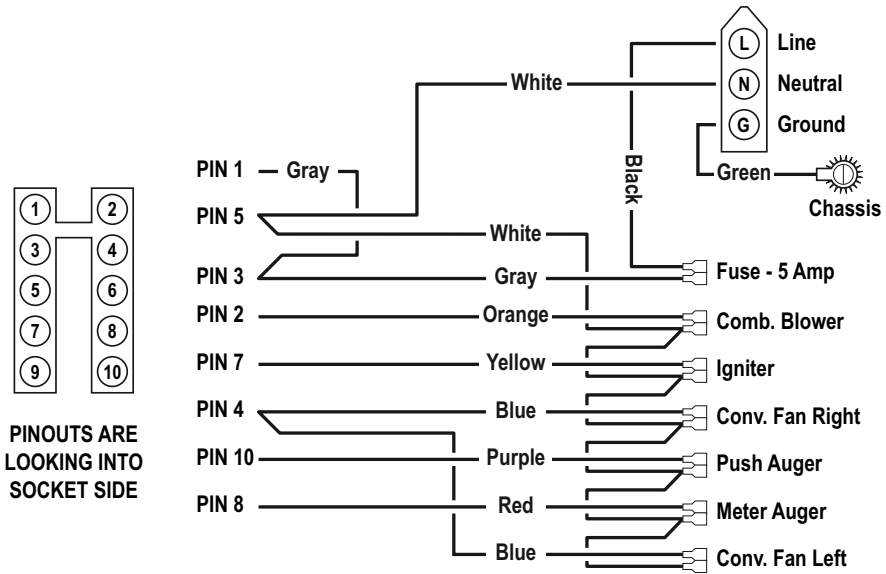

SAFETY BRANCH

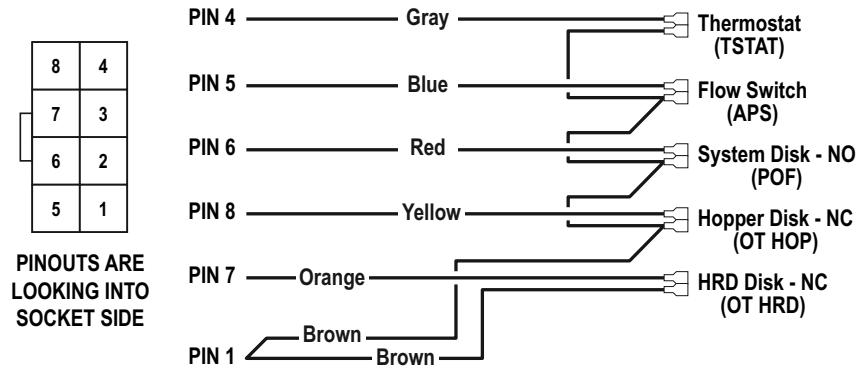

NOTE: text in parenthesis match power control board printed characters

1102

Safety Label



WARNING - DO NOT REMOVE OR COVER THIS LABEL

SERIAL NO:

MODEL: DEERFIELD

Listed Pelletized Solid Fuel Burning Appliance
Also for use in mobile homes
Certified for US and Canada

Certified to ASTM E1509, Room Heater Pellet Burning Type (UM) 84 HUD; Certified to ULC S627
Electrical Rating: 120V AC, 60 Hz, 6 Amp: Start 6 Amps, Run 5.4 Amps with blower on High
Maximum Input Rating: 6.5 lbs/hr

This pellet fired appliance has been tested and listed for use in manufactured (mobile) homes in accordance with OAR 814-23-900 through 814-23-909. Refer to the Intertek Directory of Building Products (<https://bpdirectory.intertek.com>) for detailed information.

WARNING - FOR MANUFACTURED HOMES: Must utilize outside combustion air inlet (part #99200139) or equivalent. Structural integrity of the manufactured home floor, ceiling and walls must be maintained.

Install and use only in accordance with the manufacturer's installation and operating instructions. Contact local building or fire officials about restrictions and installation inspection in your area. Use only 3 in. / 77 mm or 4 in. / 102 mm diameter listed type "L" or "PL" venting system. See manufacturer's installation instructions and local codes for precautions required for passing chimney through a combustible wall or ceiling. Do not connect this unit to a chimney flue serving another appliance. Inspect and clean exhaust venting system frequently in accordance with manufacturer's instructions.

This pellet heater needs periodic inspection and repair for proper operation. Consult the owner's manual for further information. It is against federal regulations to operate this wood heater in a manner inconsistent with the operating instructions in the owner's manual.

For use with 1/4 in. / 6 mm to 5/16 in. / 7 mm diameter pelletized wood fuels only.

Replace glass only with 5 mm ceramic glass available from your dealer.

DANGER: Risk of electrical shock. Disconnect power supply before servicing. Route power cord away from unit. Do not route power cord beneath heater.

Operate only with viewing door and ash removal tray tightly closed. Do not obstruct combustion air openings. The space beneath heater must not be obstructed. Keep all furnishings away from heater.

Minimum Clearance to Combustible Materials (Measured to Stove Top)

| | | Interior Vertical Flue Installation | Horizontal Through the Wall Installation |
|-----------|---|-------------------------------------|--|
| SIDE WALL | A | 6 in. / 153 mm | 6 in. / 153 mm |
| REAR WALL | B | ** | ** |
| CORNER | C | 3 in. / 77 mm | 3 in. / 77 mm |
| FLUE VENT | D | 2 in. / 51 mm | 2 in. / 51 mm |

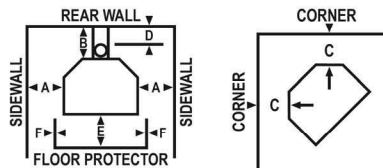

Manufactured by:



Maximum alcove depth 48 in. / 1220 mm., minimum ceiling height 60 in. / 1524 mm., minimum alcove width - See Owner's Manual

Combustible floor must be protected by a non-combustible material underneath appliance, extending to the front (E) and sides (F) 6 in. / 153 mm beyond the fuel loading and ash removal openings.

EXCEPTIONS: Non-combustible floor protection must extend beneath a vent tee when installed.

** This dimension will vary depending on brand of listed type "L" vent. See manual for details.



OMNI-Test Laboratories, Inc.
Report No. 0028PS107E

U.S. ENVIRONMENTAL PROTECTION AGENCY
Certified to comply with 2020 particulate emission standards using wood pellet fuel.
1.23 g/h, ASTM E2279-10, ASTM 2515-11, CSA B415.1-10

DATE OF MANUFACTURE: 2022 2023 2024 Jan. Feb. Mar. Apr. May June July Aug. Sep. Oct. Nov. Dec.

Made in U.S.A.

1314

Limited 7 Year Warranty

57

Register your TRAVIS INDUSTRIES, INC. Limited 7 Year Warranty online at traviswarranty.com. TRAVIS INDUSTRIES, INC. warrants this appliance (appliance is defined as the equipment manufactured by Travis Industries, Inc.) to be defect-free in material and workmanship to the original purchaser from the date of purchase as follows:

Check with your dealer in advance for any costs to you when arranging a warranty call.
Mileage or service charges are not covered by this warranty. This charge can vary from store to store.

Years 1 & 2 - COVERAGE: PARTS & LABOR

Firebox Assembly:

Fire platform, Fire platform Holder, Ash Cleanout Doors, Ash box or Ash Dump, Heat Exchanger Tubes, Exhaust Manifold, Exhaust Box

Door Assembly:

Door Frame, Latch Assembly, Glass Retainers

Auger Assembly: Auger Flight, Auger Tube, Auger Bushings, HRD

Ceramic Glass

Glass (breakage from thermal shock)

Igniter System

Igniter, Igniter Leads

Electrical System Auger Motor, Convection Blower, Exhaust Blower, Circuit Board, Snap Disks, Wiring Harness, Vacuum Switch

Re-Installation Allowance

In cases where heater must be removed from home for repairs, a partial cost of re-installation is covered (pre-authorization required)

One-Way Freight Allowance One-way freight allowance on pre-authorized repair done at factory is covered.

Exclusions: Paint, Gasketing, Chisel

Years 3 through 5 - COVERAGE: PARTS & LABOR

Firebox Assembly: Fire platform, Fire platform Holder, Ash Cleanout Doors, Ash box or Ash Dump, Cast Fireback, Heat Exchanger Tubes, Exhaust Manifold, Exhaust Box

Door Assembly: Door Frame, Latch Assembly, Glass Retainers

Auger Assembly Auger Flight, Auger Tube, Auger Bushings, HRD

One-Way Freight Allowance One-way freight allowance on pre-authorized repair done at factory is covered.

Exclusions: Paint, Gasketing, Chisel, Ceramic Glass, Igniter System, Electrical System, Cast Iron Parts, Accessories, Re-Installation Allowance

Years 6 & 7 - COVERAGE: PARTS ONLY

Firebox Assembly: Fire platform, Fire platform Holder, Ash Cleanout Doors, Ash box or Ash Dump, Heat Exchanger Tubes, Exhaust Manifold, Exhaust Box

Door Assembly: Door Frame, Latch Assembly, Glass Retainers

Exclusions: Paint, Gasketing, Chisel, Ceramic Glass, Igniter System, Electrical System, Auger Assembly, HRD, Re-Installation Allowance, One-Way Freight Allowance, Labor

CONDITIONS & EXCLUSIONS

1. This new appliance must be installed by a qualified installer. It must be installed, operated, and maintained at all times in accordance with the instructions in the Owner's Manual. Any alteration, willful abuse, accident, neglect, or misuse of the product shall nullify this warranty.
2. This warranty is non-transferable and is made to the ORIGINAL purchaser, provided that the purchase was made through an authorized Travis dealer.
3. Discoloration and some minor expansion, contraction, or movement of certain parts and resulting noise, is normal and not a defect and, therefore, not covered under warranty.
4. The warranty, as outlined within this document, does not apply to the chimney components or other Non-Travis accessories used in conjunction with the installation of this product. If in doubt as to the extent of this warranty, contact your authorized Travis retailer before installation.
5. Travis Industries will not be responsible for inadequate performance caused by environmental conditions such as nearby trees, buildings, rooftops, wind, hills, or mountains or negative pressure or other influences from mechanical systems such as furnaces, fans, clothes dryers, etc.
6. This Warranty is void if:
 - a. The unit has been operated in atmospheres contaminated by chlorine, fluorine, or other damaging chemicals.
 - b. The unit is subject to submersion in water or prolonged periods of dampness or condensation.
 - c. Any damage to the unit, combustion chamber, heat exchanger, or other components due to water, or weather damage which is the result of, but not limited to, improper chimney/venting installation.
7. Exclusions to this 7 Year Warranty include: injury, loss of use, damage, failure to function due to accident, negligence, misuse, improper installation, alteration or adjustment of the manufacturer's settings of components, lack of proper and regular maintenance, damage incurred while the appliance is in transit, alteration, or act of God.
8. This 7 Year warranty excludes damage caused by normal wear and tear, such as paint discoloration or chipping, worn or torn gasketing, chipped or cracked firebrick, etc. Also excluded is damage to the unit caused by abuse, improper installation, modification of the unit, or the use of fuel other than that for which the unit is configured.
9. Damage to gold or nickel surfaces caused by fingerprints, scratches, melted items, or other external sources left on the gold or nickel from the use of cleaners other than denatured alcohol is not covered in this warranty.
10. TRAVIS INDUSTRIES, INC. is free of liability for any damages caused by the appliance, as well as inconvenience expenses and materials. Incidental or consequential damages are not covered by this warranty. In some states, the exclusion of incidental or consequential damage may not apply.
11. This warranty does not cover any loss or damage incurred by the use or removal of any component or apparatus to or from the Travis appliance without the express written permission of TRAVIS INDUSTRIES, INC., and bearing a TRAVIS INDUSTRIES, INC. label of approval.
12. Any statement or representation of Travis products and their performance contained in Travis advertising, packaging literature, or printed material is not part of this 7-year warranty.
13. This warranty is automatically voided if the appliance's serial number has been removed or altered in any way. If the appliance is used for commercial purposes, it is excluded from this warranty.
14. No dealer, distributor, or similar person has the authority to represent or warrant Travis products beyond the terms contained within this warranty. TRAVIS INDUSTRIES, INC. assumes no liability for such warranties or representations.
15. Travis Industries will not cover the cost of the removal or re-installation of hearths, facing, mantels, venting, or other components.
16. If for any reason any section of this warranty is declared invalid, the balance of the warranty remains in effect and all other clauses shall remain in effect.
17. This 7-year warranty is the only warranty supplied by Travis Industries, Inc., the manufacturer of the appliance. All other warranties, whether express or implied, are hereby expressly disclaimed and the purchaser's recourse is expressly limited to the warranties set forth herein.

IF WARRANTY SERVICE IS NEEDED:

1. If you discover a problem that you believe is covered by this warranty, you **MUST REPORT** it to your Travis dealer **WITHIN 30 DAYS**, giving them proof of purchase, the purchase date, and the model name and serial number.
2. Travis Industries has the option of either repairing or replacing the defective component.
3. If your dealer is unable to repair your appliance's defect, he may process a warranty claim through TRAVIS INDUSTRIES, INC., including the name of the dealership where you purchased the appliance, a copy of your receipt showing the date of the appliance's purchase, and the serial number on your appliance. At that time, you may be asked to ship your appliance, freight charges prepaid, to TRAVIS INDUSTRIES, INC. TRAVIS INDUSTRIES, INC., at its option, will repair or replace, free of charge, your appliance if it is found to be defective in material or workmanship within the time frame stated within this 7-year warranty. TRAVIS INDUSTRIES, INC. will return your appliance, freight charges (years 1 to 5) prepaid by TRAVIS INDUSTRIES, INC., to your regional distributor, or dealership.
4. Check with your dealer in advance for any costs to you when arranging a warranty call. Mileage or service charges are not covered by this warranty. This charge can vary from store to store.

| | | | |
|---|--------|---|--------|
| Advanced Mode - Operation | 31 | Installation Options | 8 |
| Advanced Mode - Options..... | 30 | Installing the Pellet Vent | 12 |
| Alcove Installation Requirements..... | 14 | Introduction | 2 |
| Before You Begin | 8 | Loading Pellets | 23 |
| Check for Air Leaks..... | 48 | Manual Mode | 31 |
| Checking the Ashpan..... | 47 | Maximum Venting Distance | 11 |
| Chisel Replacement..... | 52 | Menu Button..... | 35 |
| Clean the Burn platform | 41 | Mobile Home Requirements | 13 |
| Clean the Convection Blower..... | 50 | Modes of Operation – Manual or Thermostat.. | 31 |
| Clean the Firebox Liners | 44 | Monthly Maintenance | 48 |
| Clean the Glass..... | 46 | Opening the Door..... | 40 |
| Clean the Lower Exhaust Duct | 49 | Packing List..... | 8 |
| Clean the Vent | 52 | Pellet Vent Termination | 12 |
| Clearances | 10 | Pellet Vent Type..... | 12 |
| Corner Installations | 10 | Planning the Installation..... | 9 |
| Curing the Paint | 23 | Power Outages | 38 |
| Dimensions | 7 | Removing the Door..... | 54 |
| Disposing Ashes | 39 | Replacing the Door Gasket..... | 53 |
| Door Adjustment | 48 | Replacing the Door Handle..... | 53 |
| Door and Glass Inspection..... | 48 | Replacing the Glass..... | 53 |
| Efficiency | 7 | Restrictor Adjustment | 14 |
| Electrical Specifications | 7 | Safety Notice..... | 22 |
| Emissions..... | 7 | Simple Mode - Operation..... | 26 |
| Fan Setting..... | 28, 34 | Simple Mode - Options | 25 |
| Floor Protection Requirements | 9 | Simple Mode vs Advanced Mode | 24 |
| Fuel | 7 | Starting the Heater for the First Time | 23 |
| Heater Status | 35 | Stove Maintenance | 39 |
| Heating Specifications..... | 7 | Stove Maintenance Tools | 40 |
| Important Information..... | 2 | Stove Placement..... | 9 |
| Inspect the Burn | 41 | Straight Installations | 10 |
| Installation Example: Direct "Through-the-wall" Installation | 16 | Thermostat (T-Stat) Mode | 32 |
| Installation Example: Freestanding Masonry Chimney | 21 | Thermostat Programs | 33 |
| Installation Example: Interior Vertical Installation | 17 | Touch Screen Controls | 22 |
| Installation Example: Masonry Fireplace Hearth Stove..... | 19 | T-Stat Idle Mode | 25, 30 |
| Installation Example: Zero-Clearance (Metal) Fireplace Hearth Stove..... | 20 | T-Stat or Manual Mode | 30 |
| | | Venting the Pellet Stove | 11 |
| | | Yearly Maintenance - Clean the Negative Pressure Tube..... | 51 |

Want to know more?

Scan this code with a QR reader on your cell phone or use the URL below to watch a video of how to use the Deerfield/Foxfire stove.

<https://vimeo.com/243169488>

