

# Owner's Manual

## Residential Factory Built Fireplace

---

*Operation • Maintenance • Installation*

---

# ***FOCUS 320 SBR***

Keep these instructions for future use.



Industrial Chimney Company Inc.  
400 J.-F. Kennedy, St-Jerome, QC, Canada, J7Y 4B7  
Telephone: (450) 565-6336  
[www.icc-rsf.com](http://www.icc-rsf.com)

RSF-IIF320SBR - 2022-09

**Dear Customer,**

The FOCUS 320 SBR incorporate technology with elegance to give you a beautiful view of the fire without compromising on heating efficiency or environmental quality.

We have designed your new FOCUS 320 SBR to be easy to install, operate and maintain. It is in your best interest to become familiar with it. Study your manual to be sure that the installation is correct, then follow the guidelines for operation and maintenance.

We at **RSF Woodburning Fireplaces** congratulate you on your choice of the FOCUS 320 SBR, and are confident that you have purchased a fireplace that is *simply, the best*.

Sincerely,

RSF Woodburning Fireplaces Team

---

## TABLE OF CONTENTS

<b>SAFETY FIRST</b>	<b>2</b>	<b>INSTALLATION</b>	<b>11</b>
Do's and Dont's	2	Location	11
Creosote: Formation and Removal	2	Mobile Home Installation	14
<b>GENERAL SPECIFICATIONS</b>	<b>3</b>	Ceiling Clearance	14
The Combustion Control System	3	Standoffs Installation	14
Options	3	Securing the Fireplace in Place	15
Unit Dimensions and Clearances	5	Outside Air Duct	15
<b>OPERATION</b>	<b>7</b>	Mandatory Options	16
Air Controls	7	Chimney	16
Improving efficiency	7	Chimney Installation	17
Importance of draft	7	Offset Chimney	17
Burn Time vs Heat Output	7	Chase Enclosure	19
Fuel	7	Masonry Chimney	19
First Fires	8	Covering the Fireplace Facing	20
Lighting	8	Mandatory Options with the Clean Face	21
Refueling	8	Hearth Extension	21
Troubleshooting Problems	9	Beneath Hearth Extension	21
<b>MAINTENANCE</b>	<b>9</b>	Mantel	21
Chimney Cleaning	9	Refractory Brick Installation	22
Disposal of Ashes	9	Baffle	22
General Cleaning	10	<b>LISTING LABEL</b>	<b>23</b>
Glass Cleaning	10	<b>COMPLETE OPTIONS LIST</b>	<b>24</b>
Paint	10	<b>CONFIGURED OPTIONS LIST</b>	<b>26</b>
Door Adjustment	10	<b>REPLACEMENT PARTS</b>	<b>27</b>
		<b>LIMITED WARRANTY</b>	<b>29</b>

# SAFETY FIRST

## DO'S AND DONT'S

If this fireplace is not properly installed, a house fire could result. For your safety, follow the installation directions. Contact your local authority having jurisdiction (such as municipal building department, fire department, fire prevention bureau, etc.) regarding restrictions and installation requirements, and the need to obtain a permit.

This wood heater needs periodic inspection and repair for proper operation. It is against federal regulations to operate this wood heater in a manner inconsistent with operating instructions in this manual.

To ANYONE using this fireplace: these **DO's** and **DONT's** are for your safety.

1. **DO** read this instruction manual before lighting your first fire.
2. **DO** burn seasoned wood fuel or a combination of densified fuel logs and wood fuel.
3. **DO operate the fireplace with the door fully closed.** If the door is left partly open, gas and flame can be drawn out of the fireplace opening, creating both fire and smoke hazards.
4. **DO** keep all combustible materials (furniture, firewood, etc.) at least 4' away from the front of the fireplace.
5. This fireplace needs periodic inspection and repair for proper operation. **DO** learn to properly use it and maintain it.
6. **Do** have at least one smoke detector on each level of the house and at least one carbon monoxide detector.
7. To avoid glass breakage, **DO NOT** slam the fireplace door.
8. **DO NOT** ever use gasoline, gasoline-type lantern fuel, kerosene, charcoal lighter fluid or similar liquids to start or freshen up a fire in this fireplace. Keep all such liquids well away from the fireplace while it is in use.
9. **DO NOT overfire the fireplace. If you are unable to slow down the burn rate of the fire or if the chimney connector behind the top louver glows red, you are overfiring the fireplace.**
10. **DO NOT** use a fireplace grate or other products not specified for use with this fireplace.
11. The burn rate is set by the automatic air control at the factory. **DO NOT** tamper with the air control. **DO NOT** install a flue damper that would allow you to reduce the chimney draft and thus slow the minimum burn rate.
12. To avoid damaging the fireplace, **DO NOT** operate it in a manner inconsistent with the operating instructions in this manual.
13. **DO NOT** install an insert in this fireplace.



◆ **NOTE:** We strongly recommend that our products be installed and serviced by professionals who are certified by the National Fireplace Institute in the U.S. or by Wood Energy Technology Transfer Inc. in Canada.



## CREOSOTE: FORMATION AND REMOVAL

When wood is burned slowly, it produces tar and other organic vapors which combine with the expelled moisture from the wood to form creosote. The creosote vapors can condense in the relatively cool chimney of a slow burning fire. As a result, creosote residue accumulates on the flue lining. When ignited, this creosote makes an extremely hot fire.

The chimney should be inspected periodically during the heating season to see if a creosote build-up has occurred. The presence in a chimney of soot or creosote in excess of 1/8" (3mm) thick will indicate the need for immediate cleaning, possible modification of burning procedures, and more frequent inspections.

❖ **WARNING: USE SOLID FUEL ONLY. BURN DRY WOOD ONLY.**  
**DO NOT BURN: UNSEASON WOOD, DRIFTWOOD, TREATED WOOD, COAL, COLORED PAPER, CARDBOARD, TRASH, GARBAGE, OR PLASTIC.**

Do not use construction scraps (e.g. 2x4 or plywood scraps) as your only supply of fuel as you can overheat and seriously damage the fireplace.

We do not recommend using wax fuel logs (e.g. Duraflame) in this fireplace because it will dirty the glass. If you choose to use wax or densified firelogs, do not use more than one at a time and do not poke or stir the logs while they are burning. Use only firelogs that have been evaluated for fireplace use. In Canada, they must meet the requirements of ANSI/CAN/UL/ULC 2115, Processed Solid Fuel Firelogs and Firestarter. Refer to the firelog warnings and caution markings on packaging prior to use.

---

## **GENERAL SPECIFICATIONS**

The FOCUS 320 SBR is environmentally friendly and meets the 2020 United States Environmental Protection Agency (EPA) particulate emission standard with crib wood at an emission rate of 1.4 grams per hour.

The FOCUS 320 SBR has an efficiency of 65.9% with a maximum heat output of 22 563 BTU/hr. These results were measured in a test lab environment and were established using the higher heating value of the wood, as well as data from a crib wood EPA emission test and using CSA B415.1:22 calculations.

Consumers may experience different results. It has been demonstrated in a test laboratory that the heat output range varies with the type of installation, chimney height, cordwood used, etc. Please refer to the "Improving efficiency", the "Importance of draft", the "Burn Time vs Heat Output" and the "Fuel" sections to better understand the various factors that influence the efficiency and heat output of your fireplace.

### **THE COMBUSTION CONTROL SYSTEM**

Since the door is sealed, all combustion air must come through the fireplace's draft control. The draft control is an assembly that increases or reduces the amount of air permitted into the firebox. A bi-metallic coil in the air control allows more air when the unit is cold, and less air when the unit is hot, guarding against overheating. The air control is fully automatic; there is no user access to the air control.

Control the fire as you would any normal fireplace, using one or two logs at a time for a smaller fire, or more logs for more heat. Remember: when the fireplace is hot, the automatic air control will reduce the combustion air inlet since the bi-metallic coil will shut the air control damper part way.

### **OPTIONS**

#### **Louver Options**

There are different ways you can finish your fireplace<sup>1</sup>. You can choose to install louvers (black blade style FO-F320SBRLB) or no louvers at all<sup>2</sup> (FO-F2).

If you choose to install your fireplace without any louvers, you MUST install the Clean Face Option (FO-F2) along with two Gravity Vent Kits (FO-V2 or FO-V3). Gravity vent dampers CANNOT be installed on a Clean Face fireplace. Furthermore, we recommend that you do not install any option requiring electricity or a thermal switch inside your fireplace since it will be difficult to access those components after the fireplace facing is covered with non-combustible materials. If you decide nevertheless to install electricity or a thermal switch in your Clean Face fireplace, remember that you may eventually have to break through the non-combustible finishing to access the electrical box or the thermal switch for servicing.

#### **Gravity Vent Options**

Gravity vent kits<sup>3</sup> allow hot air to be ducted from the fireplace to a room above or on the same level as the fireplace. Clean Face installations require two gravity vents for heat circulation.

Each gravity vent kit includes 5' of insulated flexible ducting, a fireplace adapter, an outlet grill adapter, and a decorative outlet grill.

---

<sup>1</sup> You can also refer to the configured option list on page 24.

<sup>2</sup> Not allowed in a mobile home installation.

<sup>3</sup> Not allowed in a mobile home installation.

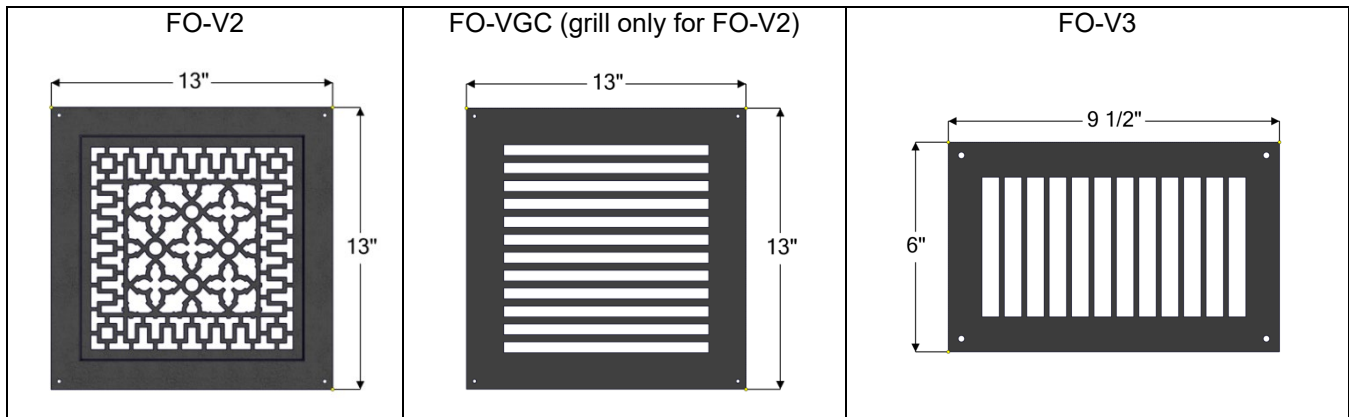

Additional 5' lengths of insulated flexible ducting can be ordered with the part code FO-DUCT5. Nevertheless, gravity vents have a maximum length of 15'.

### **Heating Options**

For increased air circulation and marginally more heat output, you can add the Circulating Internal Blower (FO-HB9) to your Louvered fireplace or the Inline Fan (FO-CIF) to your Clean Face fireplace.

◆ **NOTE:** The FOCUS 320 SBR is equipped with a floor shield to protect the floor under the fireplace. This floor shield is made of two parts: the front part is insulated; the back part is a single layered sheet metal. Both parts are screwed together and factory installed to cover the entire floor below the firebox. It must never be removed. Only when installing the Internal Blower Option can the floor shield be modified. Follow the internal blower installation instructions but before reinstalling the floor shield, remove the screw, slide the back part over the front part and screw them back together. If you ever remove the internal blower make sure to extend the shield again.

To maximize the distribution of the heat generated by your fireplace throughout many rooms and different floors, consider the Central Heat Option<sup>4</sup>. With our Central Heat Blower (FO-FDHB6-1), you can use ducts to circulate the fireplace heat to one or many rooms. The Central Heat Control (FO-FDHC6) will enable automatic control of the Central Heat Blower via a wall thermostat and thermal switch. The Zone Heat Control (FO-FDHCZ1) along with Zone Damper Kits (FO-FDHCZ2) will provide the same features as the Central Heat Control but for more than one heating zone. If you wish to install the Central Heat Blower on a Clean Face fireplace, you will need the Central Heat T (FO-T) that will enable you to connect the central heat duct along with the left gravity vent on the fireplace.

For a simple way to circulate a moderate amount of warm air from the fireplace to another room, we offer the Heat Dump Kit (FO-HD). It includes a 180 cfm blower and is most often used to provide supplemental heating to a basement room when the fireplace is on the main floor, but it can also be used to send the warm air to an adjacent room or upstairs. The duct maximum length is 8' for the FO-HD.

### **General Options**

To simplify the installation of thin non-combustible materials such as ceramic tile or sliced brick, we have designed a rock retainer kit. It is not designed or required for full brick or stone. With a Louvered fireplace, you can choose to leave all the black metal completely exposed or completely covered with non-combustible material. Whether you have chosen a Louvered or Clean Face fireplace, the FO-KN kit will help you finish the facing of the fireplace as you wish. Thin materials can also be installed directly on the face of the fireplace using high temperature silicone as glue, without a rock retainer kit.

Decorative andirons (FO-A) are also an optional feature. The decorative andirons are made of cast iron and are more aesthetically appealing than the basic ones included with the fireplace. The decorative andirons are also taller, which reduces the chance of logs rolling forward.

◆ **NOTE:** Many options require wiring and/or electricity for their installation. If there is any chance that any of these options will be installed in the future then suitable wiring should be run during framing. Otherwise, it will be difficult to install these options later. You can refer to page 24 for a list of options that require electricity.

Detailed installation instructions are included in the box with each option. These can also be obtained from our Internet Web Site: [www.icc-rsf.com](http://www.icc-rsf.com).

<sup>4</sup> Not allowed in a mobile home installation.

❖ **WARNING: THIS FIREPLACE HAS NOT BEEN TESTED WITH A GAS LOG SET (UNVENTED OR VENTED). TO REDUCE RISK OF FIRE OR INJURY, DO NOT INSTALL A GAS LOG SET (UNVENTED OR VENTED) INTO THIS FIREPLACE. DO NOT INSTALL A GAS LOG LIGHTER BECAUSE THE HEAT PRODUCED BY THE FIREPLACE WILL PERMANENTLY DAMAGE THE GAS LOG LIGHTER.**

**UNIT DIMENSIONS AND CLEARANCES**

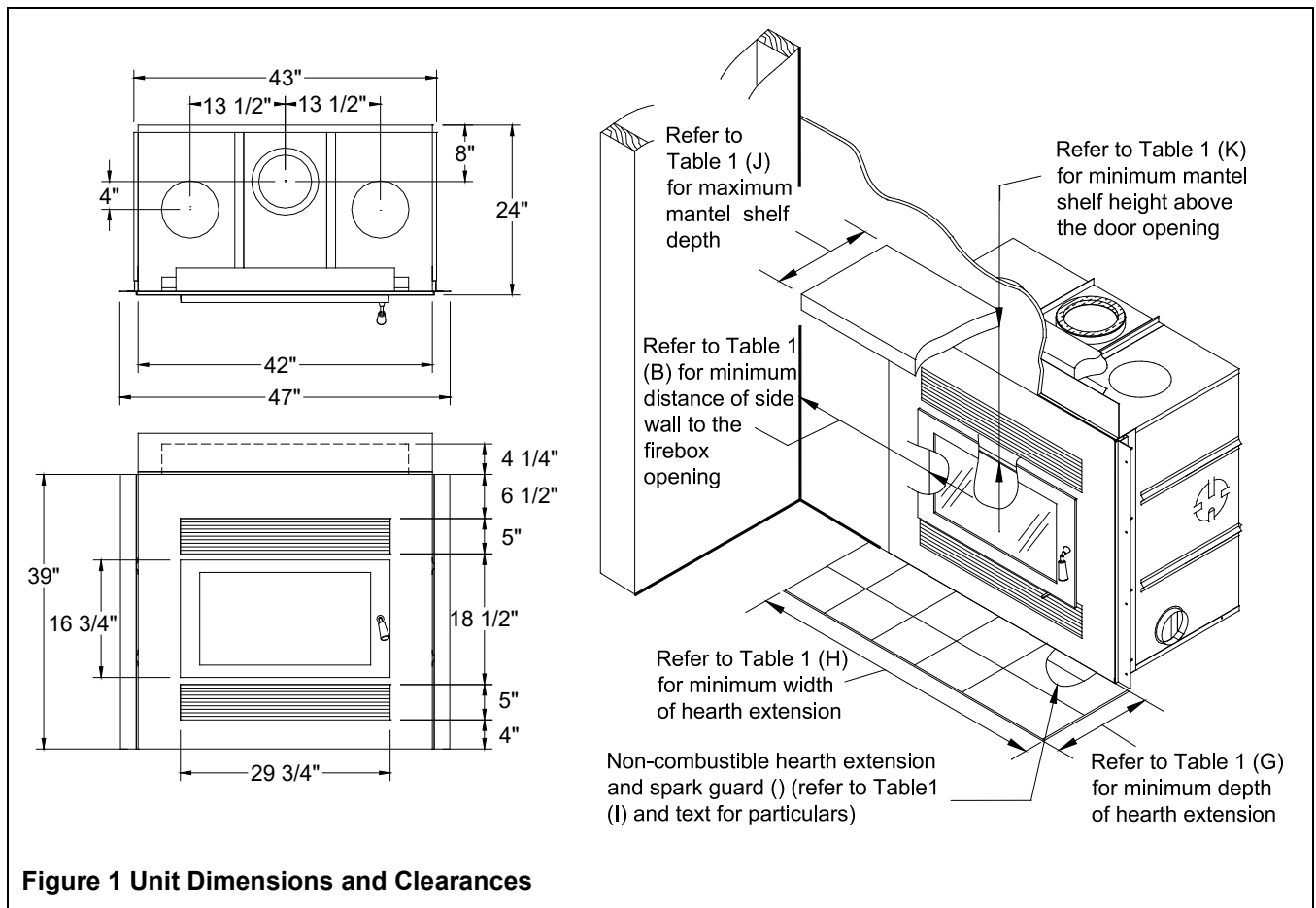

**Table 1 Unit Dimensions and Clearances**

A	Distance of combustible material from side, back and top standoffs	0" (0,0 mm)
B	Minimum distance from the side wall to the side of the firebox opening	12" (305 mm)
C	Minimum ceiling height: measured from the base of the fireplace to the lowest point of the ceiling above the fireplace. Applies both to the inside and outside of the fireplace enclosure.	sealed enclosure 7' (2,13 m)
		vented enclosure 6' (1,83 m)
D	Minimum chimney height: minimum total chimney height from fireplace top to below the chimney rain cap – Refer to Table 3 on page 16 if elbows are present	12' (3,66 m)
E	Maximum chimney height: maximum total chimney height from fireplace top to below the chimney rain cap	40' (12,19 m)
F	Maximum chimney height supported by the fireplace	18' (5,49 m)
G	Minimum depth of non-combustible hearth extension: from the front of the fireplace	20" (508 mm)
H	Minimum width of non-combustible hearth extension: total width, must be centered on the firebox opening	42" (1,07 m)
I	Minimum width of the spark guard	36" (914 mm)
J	Maximum mantel shelf depth (see Table 2 for other mantel sizes)	12" (305 mm)
K	Minimum height of a combustible mantel shelf above the top of the firebox opening: to the bottom of the combustible mantel (refer to the "Installation: Mantel" section for particulars)	See Table 2

**Table 2 Various Mantel Shelf Depths and Corresponding Installation Heights**

Maximum Mantel Shelf Depth	Minimum Installation Height
0" to 6"	20"
12"	26"

No combustible mantel shelf can be installed lower than 20" above the top of the firebox opening. A combustible mantel shelf cannot be deeper than 12".

For any combustible mantel shelf depths between 6" and 12", you can calculate the minimum installation height. For example:

- Mantel shelf depth to be installed: **9¼"**
- So:  $(9.25 - 6) + 20 = 23.25 = 23¼"$
- Thus, minimum installation height of a **9¼"** mantel: **23¼"** above the firebox opening

If the combustible mantel shelf has a cross-section with variable depth, it has to be installed so that its widest part is not installed lower than the corresponding minimum installation height while making sure that the lowest point of the mantel is not installed lower the minimum installation height corresponding to it depth.

Refer to the "Installation: Mantel" section for particulars.

---

---

## **OPERATION**

### **AIR CONTROLS**

#### **Combustion Air Control**

The bi-metallic coil is a unique feature built into your fireplace. It serves as a fully automatic combustion air control.

As the fireplace heats up, it will activate the bi-metallic coil. This will automatically begin to shut down the air entering the firebox, slowing the combustion process. This will save you wood, reduce emissions, improve efficiency, and prevent the fireplace from overheating and causing potential damage to the firebox.

#### **Outside Air Control**

The FOCUS 320 SBR is designed to use outside air for combustion.

Because outside air is generally colder and denser it will help to start the fire. In some cases, fresh air will help compensate for negative pressure problems within the house; however, it will not prevent the fireplace from smoking in a severely depressurized house.

We recommend always using outside air for combustion, but you may choose to use room air for combustion instead. You will find a sliding door behind the bottom louver and below the firebox. Push the sliding door towards the back to select outside air or pull it toward the front to select inside air as the combustion air.

If the fireplace is installed in a mobile home, the outside air **MUST** be used as combustion air.

### **IMPROVING EFFICIENCY**

The location of your fireplace will affect how efficiently it heats the home. Your fireplace should be located in part of the house you want to be the warmest. Trying to heat the main floor with a fireplace in the basement will generally overheat the basement and waste fuel. Certain RSF options offer the ability to move heat from the main floor to the basement. This allows you to efficiently heat your primary space while also heating the basement as a secondary space.

The efficiency can also be influenced by various factors such as the draft in the chimney (refer to "Importance of draft" below), the amount of wood burning at any point (see "Burn Time vs Heat Output" below) and the quality of the wood (refer to "Fuel" below).

All of these factors must be considered and optimized in order to recover the maximum heat from your fireplace.

### **IMPORTANCE OF DRAFT**

Draft is the natural force which pulls air from the fireplace up the chimney. The strength of draft in your chimney depends on a variety of factors, including chimney height, nearby obstructions, altitude, etc.

Excessive draft can result in a hotter fire than intended or reduced burn times as more air is pulled through the fireplace. It will also result in less heat recovery since the heat will not have as much time to radiate into the room before being sucked into the chimney.

Weak draft can result in smoke entering the room and difficulty lighting or operating the fireplace. Weak draft is often incorrectly associated as a blockage in the air intake for the fireplace. Adding chimney height is the most common solution. See Table 3 for minimum chimney height recommendations.

### **BURN TIME VS HEAT OUTPUT**

The faster your fireplace burns the more heat it will create; however, faster fires result in much more hot air flow up the chimney which means you are sacrificing efficiency. Fast burning fires (lots of air) go through much more wood than slow burning fires. Your fireplace burns at a fixed rate depending on the heat inside the firebox. It will burn quickly during light up and then gradually slow down to offer the best efficiency and emissions reduction.

### **FUEL**

All modern high efficiency fireplaces and woodstoves are designed to burn best with seasoned cordwood. Seasoned wood can be defined as wood that has been cut, split and let dry under cover for a minimum of 6 months, preferably



a year or more. Dry seasoned wood generally contains less than 20% moisture content. Attempting to burn fuel with a high moisture content will be difficult and result in lower efficiency, increased creosote buildup and dark deposits on the glass. It is possible to burn a very large amount of wood and get very little heat if the wood is wet.

The type of wood you select is also important. All types of wood give off more or less the same number of BTU's per pound. Since softer woods are less dense than hardwoods it is possible to put more weight of hardwood in the firebox; in other words, all woodburning appliances will burn longer and more evenly with hardwoods. Never burn scrap, garbage, treated wood or driftwood as they produce much more pollution and can corrode the firebox and chimney as well. Burning large amounts of paper, cardboard, mill ends, or construction waste can easily over fire and damage the fireplace or even ignite a chimney fire if the flue is dirty.

## **FIRST FIRES**

You will experience a slow start-up during the first few fires. The refractory bricks lining the firebox contain moisture from manufacturing and require a few hot fires to evaporate the moisture. While there is still moisture in the bricks, they will be black with smoke deposits. When the moisture has dissipated, the bricks will turn white. Unlike cast iron stoves, there is no need to cure the fireplace itself by starting with small fires and progressively larger ones. Feel free to light a large fire from the very start.

You will experience a slight odor during the first few fires. This odor comes from curing paint and oil burning off the metal. The odor may be strong enough to set off your smoke detector. Open the doors and windows to allow the room to properly ventilate.

## **LIGHTING**

Start by laying your fire starter and kindling. Traditional fire starter is crumpled newspaper; make sure to use enough to light the kindling (5-6 pieces should do). Next lay 3 or 4 layers of kindling crisscrossed over the newspaper. Using plenty of kindling ensures that the chimney will heat up quickly and establish a strong draft, **never use any flammable liquids**. Light the paper and close the door most of the way, but don't shut it completely, keep it about 1" from being completely closed. If the door is positioned correctly you will see air rushing into the fireplace, this will help the lighting process.

Once the kindling is lit and sustaining fire, you can add some small pieces of seasoned cordwood. Use the andirons in front to help position the cordwood so as not to flatten and smother the fire you've just created. Always add at least 3 pieces of cordwood. Position your cordwood in a manner that the fire will hit several pieces as it rises and has air gaps to flow through. Continue to leave the door slightly open until the cordwood is lit, about 3-5 minutes. Close the door completely when the fire is established.

During light up, it is normal for the glass to accumulate some soot and become dark. As the fireplace heats up, this should burn off and reveal a nice view of the fire.

❖ **WARNING: DO NOT USE A GRATE OR ELEVATE THE FIRE.**

❖ **WARNING: MAKE SURE TO KEEP THE FIRE BEHIND THE ANDIRONS. REPOSITION THE LOGS IF THEY FALL AGAINST THE GLASS.**

## **REFUELING**

Have your next wood load ready when you open the door. The temperature in the firebox will decrease dramatically while the door is open, so decreasing the amount of time the door is open will allow the firebox to remain hotter. Nevertheless, do not rush.

Turn off the central heat and/or internal blowers, if installed. The blowers may cause smoke to spill out of the fireplace if they are running.

The door should be opened slowly to keep smoke from spilling into your room. If you have a problem with smoke spillage, check to see that all kitchen and bathroom fans have been shut off. They can cause negative pressure in the house which pulls smoke out of the fireplace.

Take the time to poke and stir the unburnt wood that is left in the firebox. This will help revive the fire. Place the new logs in the firebox. Try to maintain a clear path in front of the pilot, which is the metal tube centered between the two andiron posts. The pilot brings an influx of air close to the coals that will help to keep the fire going. Once the new wood has been loaded, keep the door slightly ajar for about 3-10 minutes to get the fire going depending

on how well seasoned your cordwood is and how much coals were left in the firebox. Once the new wood is well lit, close the door.

Wait at least 15 minutes after shutting the door after reloading before turning any blowers back on. This ensures that heat will built up in the firebox before being cooled by the blower and ensures that your fireplace will continue on burning as clean as it can.

## **TROUBLESHOOTING PROBLEMS**

If smoke comes into the house when the door is opened:

- You may have opened the door too quickly and created a suction of air into the room, this can be avoided by opening the door more slowly.
- Ensure your chimney is clean and your chimney cap is not plugged. Chimney caps with screens are more likely to become clogged with creosote buildup.
- Make sure you have adequate chimney height for your system. Refer to the Chimney section of this booklet and make sure to take altitude, and number of elbows into consideration.
- If you have purchased the central heat kit option or the circulating internal blower, make sure the blower is off before opening the door.
- Check to see if other fans in the home are running, particularly a kitchen range hood, or bathroom exhaust fan. This can affect the pressure in the home.
- Try opening a window near the fireplace a little, this will equalize the pressure in the home and should correct a draft problem. Once proper draft is established the window can be closed.
- Make sure you've used enough kindling to establish a hot fire quickly. The most likely time that smoke will enter the home is during the lighting process.

If your fireplace burns excessively fast, seemingly uncontrollably:

- Check all door seals and gaskets to ensure that air is not leaking into the firebox. See "Door Adjustment" for details of how to verify the tightness of the door.
- Inspect the secondary air tubes in the top of the fireplace to ensure they are in good condition. An unwanted hole in the secondary air tubes can bring additional unwanted air into the fireplace.

---

## **MAINTENANCE**

### **CHIMNEY CLEANING**

Check the chimney for creosote buildup every week or so until experience shows how often you need to clean it. A buildup of 1/8" (3 mm) or more should be cleaned before more creosote accumulates. Close the fireplace door(s) prior to sweeping. Use an 7" round brush.

We do not recommend moving or removing the baffle for chimney sweeping. The top part of the baffle is a metal plate that can be easily vacuumed after sweeping the chimney. Be careful not to get too close to the sides and back of the firebox with the vacuum nozzle. The soft white insulation can be easily torn and swallowed.

Nevertheless, if you prefer to remove the baffle, you will have to remove both side refractory bricks (see the "Refractory Brick Installation" section for detailed instructions), then remove the front secondary air tube (remove the cutter-pin on the left) and then the baffle (see "Baffle" section for detailed instructions). Make sure to reinstall everything correctly after cleaning.

### **DISPOSAL OF ASHES**

Remove the ashes before they become too deep, i.e., before you have a spillage problem when you open the door.

The ashes should be placed in a metal container with a tight-fitting lid. The closed container of ashes should be placed on a non-combustible floor or on the ground, well away from all combustible materials pending final disposal. If the ashes are disposed of by burial, or otherwise locally dispersed, they should be retained in the closed container until all cinders have thoroughly cooled.

## **GENERAL CLEANING**

The high heat paint can be cleaned with a soft damp cloth. Use a mild detergent and water. Do not use abrasive cleaners.

## **GLASS CLEANING**

In a controlled combustion firebox, temperatures are not always high enough to keep the glass perfectly clean. A good hot fire once a day usually cleans off most of the deposits that have accumulated. Remember: the drier the wood and the hotter the fire, the cleaner the glass. A word of caution: although heat will not break the glass, impact can. Be careful not to hit the glass.

❖ **WARNING: NEVER CLEAN THE GLASS WITH AN ABRASIVE CLEANER. USE ONLY A CLEANER RECOMMENDED BY YOUR DEALER. NEVER CLEAN THE GLASS WHILE IT IS HOT, A SERIOUS BURN CAN RESULT. THERE ARE A NUMBER OF EXCELLENT WOOD STOVE GLASS CLEANERS AVAILABLE WHICH ARE FAR SUPERIOR TO REGULAR GLASS AND OVEN CLEANERS FOR WOOD STOVE APPLICATIONS.**

## **PAINT**

❖ **WARNING: AVOID SPRAYING CERAMIC GLASS CLEANER OR OTHER CLEANERS ON THE PAINT OF THE FIREPLACE. THEY MAY REMOVE THE PAINT AND MAKE TOUCHUPS DIFFICULT.**

You can touch up the face of your fireplace with *Stove Bright* Metallic Black high temperature paint which is available at most fireplace dealers. Follow the directions outlined on the spray can. **DO NOT** attempt to paint the fireplace while it is still warm. Keep the spray can away from any source of heat or open flame. Ensure that there is adequate ventilation in the room from the time you start painting until the paint is dry. *Stove Bright* is available in a wide range of colors if you want to change the color of your fireplace.

We recommend that you take the time to protect or remove any item that you do not want to paint such as: the door glass, the fireplace surroundings, etc. The glass can be removed from the door but you will have to replace the gasket.

## **DOOR ADJUSTMENT**

To check for a proper door seal, insert a sheet of paper between the door and the front of the fireplace and latch the door. Pull gently but firmly on the sheet of paper. If the paper either tears or is hard to retrieve, the adjustment is correct. Repeat this procedure along all sides of the door.

The most important factor for controlling the burn rate of your fireplace is a good seal on the door gasket. If the door gasket is worn or damaged to the point where the seal is not adequate as described above, then remove and replace the gasket. Replacement kits are available from your RSF dealer.

The door latch is progressive, the more you turn the handle the tighter the seal on the right side of the door. Beware not to always over tighten the door latch; this will result in premature failure of the door gasket or cause undue stress on the door handle.

If needed, the hinges can be adjusted to improve the alignment of the door latch with respect to the hole in the fireplace facing, and for easy installation/removal of the door.

◆ **NOTE:** An improperly adjusted door seal can have a significant effect on the performance and durability of the fireplace. A poorly adjusted door can result in reduced efficiency, over firing, excessive wood consumption and premature fireplace failure.

## INSTALLATION

Check with your local authority having jurisdiction (such as municipal building department, fire department, fire prevention bureau, etc.) regarding restrictions and installation requirements, and the need to obtain a permit.

♦ **NOTE:** We recommend that you remove the door until after all finishing work is completed around the fireplace. This will reduce the possibility of scratches, vandalism, or damage to the finish caused by gypsum dust, muriatic acid, plaster, cement, paint or any other harmful spray or liquid.

### LOCATION

Your FOCUS 320 SBR fireplace may be installed in many different ways (see Figure 2) without any special floor reinforcement. We recommend that you take the time to plan your entire installation (fireplace, chimney, and options) before beginning the actual installation (refer to Figure 3 and Figure 4).

Dimensions of the fireplace along with clearances are shown in Figure 1 and Table 1.

❖ **WARNING: IF THIS FIREPLACE IS NOT PROPERLY INSTALLED, A HOUSE FIRE CAN RESULT. FOR YOUR SAFETY, FOLLOW THE INSTALLATION INSTRUCTIONS AND CLEARANCES. DO NOT PACK REQUIRED AIR SPACES WITH INSULATION OR OTHER MATERIALS.**

1. Note the location of roof and floor joists. Try to choose a location that does not require cutting them.
2. If possible, run the chimney up through the inside of the house. If it must be run outside, it should be enclosed in an insulated enclosure (see "Installation: Chase Enclosure"). Remember, a cold chimney causes poor draft.

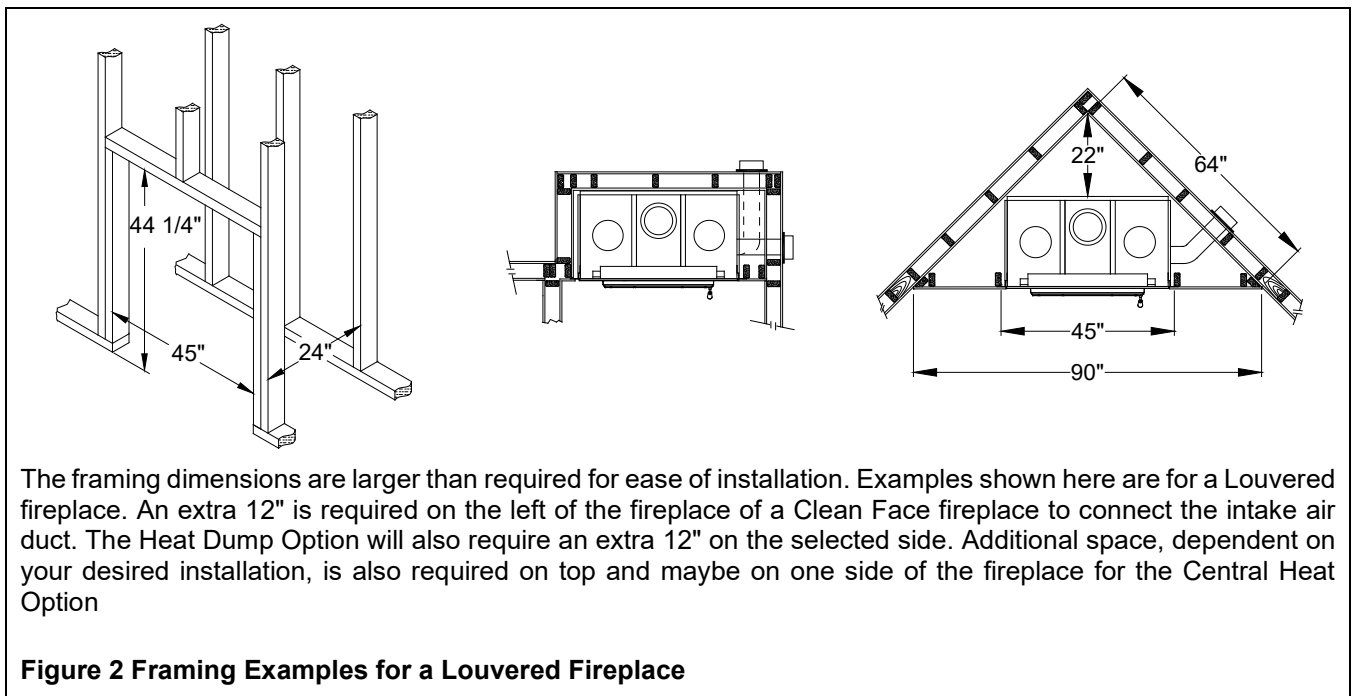

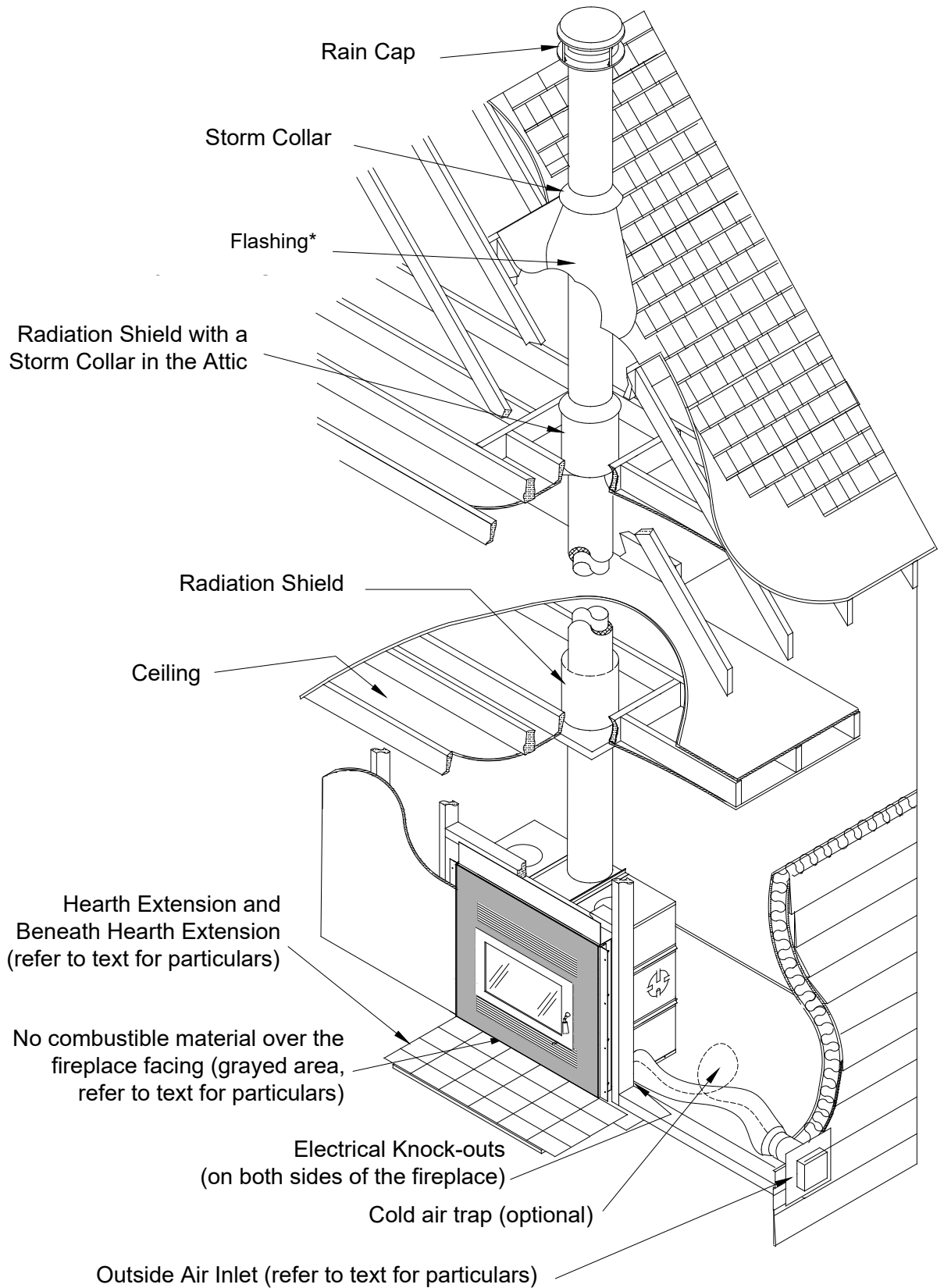

\*Refer to text to determine the appropriate flashing

**Figure 3 Louvered FOCUS 320SBR General Installation**

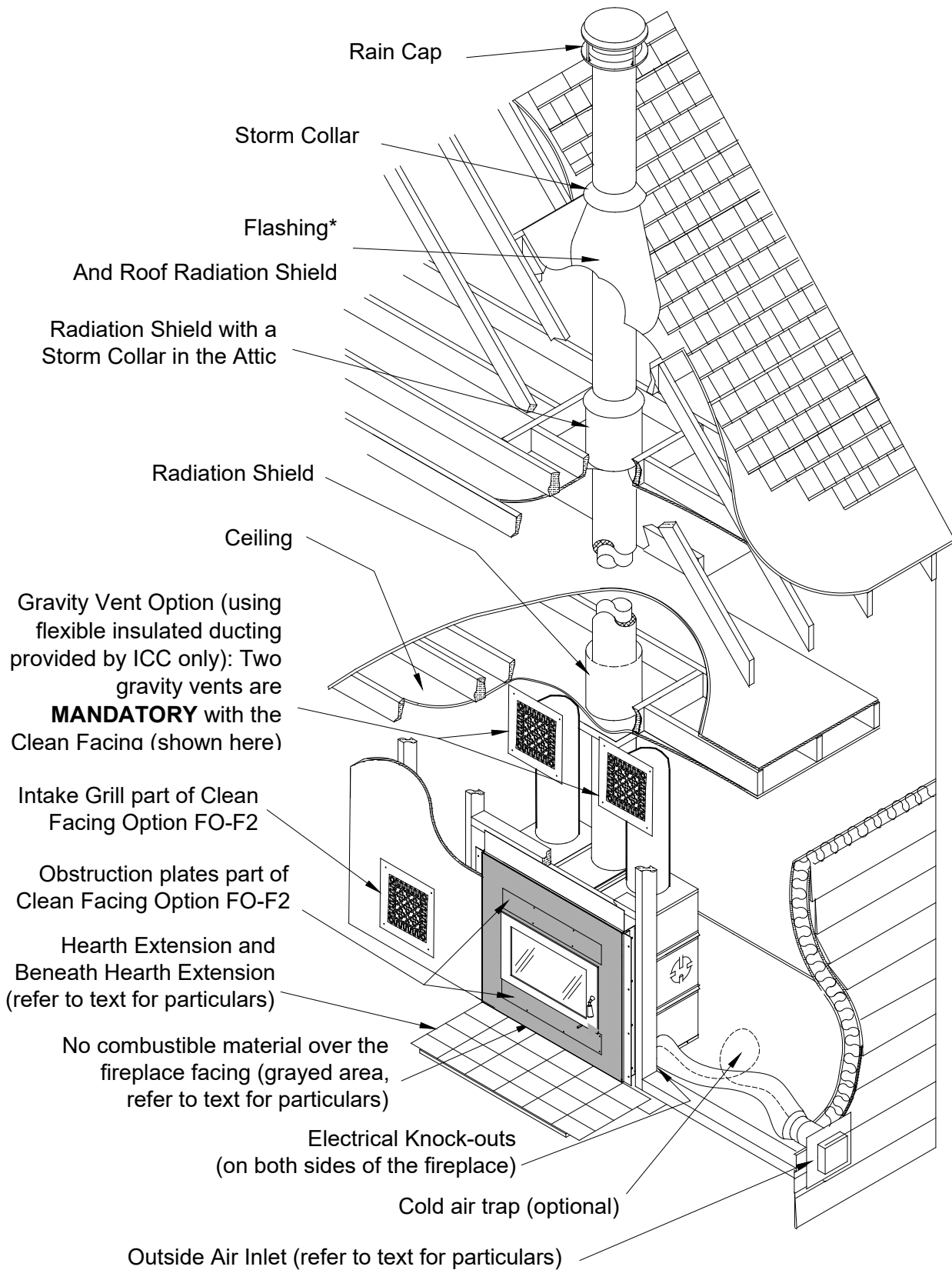

\*Refer to text to determine the appropriate flashing

**Figure 4 Clean Face Fireplace General Installation**

## **MOBILE HOME INSTALLATION**

The installation of your fireplace is the same whether you install it in a regular home or in a mobile home. Nevertheless, you **MUST** comply with the following restrictions:

1. You **MUST** use a vented roof flashing.
2. You **CANNOT** install gravity vents.
3. You **CANNOT** install the central heating system.
4. You **MUST** use outside air as combustion air.

❖ **WARNING: IF YOU PLAN ON INSTALLING YOUR CHIMNEY WITH AN OFFSET THROUGH THE WALL OF THE MOBILE HOME, VERIFY WITH THE AUTHORITIES HAVING JURISDICTION REGARDING THE OBLIGATION OF ENCLOSING THE CHIMNEY ON THE OUTSIDE OF THE MOBILE HOME.**

❖ **WARNING: DO NOT INSTALL IN SLEEPING ROOMS.**

Make sure to provide access openings to the fireplace and chimney enclosures. These access openings must be covered on a regular basis but must be easily opened to allow inspection of the installation and clearances after any move of the mobile home.

Before using the fireplace, make sure that nothing is blocking the outside air inlet to freely allow outside air into the fireplace. Review tips provided in the "Troubleshooting Problems" section on page 8 regarding potential issues with household fans and depressurized homes.

Be aware that burning wood generates carbon monoxide; make sure it does not accumulate inside the mobile home.

Be also aware that depending on your smoke detector location with respect to the fireplace, your smoke detector may give you false alarms when the fireplace is being used.

Be careful, if you ever decide to renovate around the fireplace. Clearances around the fireplace and the chimney **MUST** always be respected.

A radiation shield must be installed, as usual, at each floor where the chimney passes through. The ICC part is long enough to extend to the outermost plane of the roof, which it must also protect.

❖ **CAUTION: THE STRUCTURAL INTEGRITY OF THE MANUFACTURED HOME FLOOR, WALLS AND CEILING/ROOF MUST BE MAINTAINED.**

## **CEILING CLEARANCE**

Ceiling clearance is the distance from the base of the fireplace to the ceiling. If you vent the fireplace enclosure, you can then have a lower ceiling clearance as specified in Table 1 (C) for a vented enclosure.

For a vented enclosure, you **MUST** install regular venting 3"x10" grilles or larger into holes cut within 1' of both the floor and the ceiling, to allow room air to circulate through the fireplace enclosure and reduce heat buildup. These venting grilles may be placed vertically or horizontally.

Under no circumstances should the distance between the ceiling firestop and the base fireplace be less than the dimension specified in Table 1 (C).

## **STANDOFFS INSTALLATION**

Before you begin installing your fireplace, you **MUST** install the standoff provided on both sides of the fireplace and on the top. Please refer to Figure 5 to position them adequately. These standoffs provide the appropriate clearances for combustible wall covering and combustible framing around the fireplace. Do respect these clearances.

Aligning the front edge of the return on all three standoffs with the facing of the fireplace will provide a guide for the front face of the wall covering to align with the front face of the fireplace. The top standoff **MUST** have the back shield bent at a 45° angle and be screwed centered to the top of the fireplace casing using the self-tapping screws provided. The side standoffs **MUST** be screwed to both sides of the fireplace casing using the self-tapping screws provided.

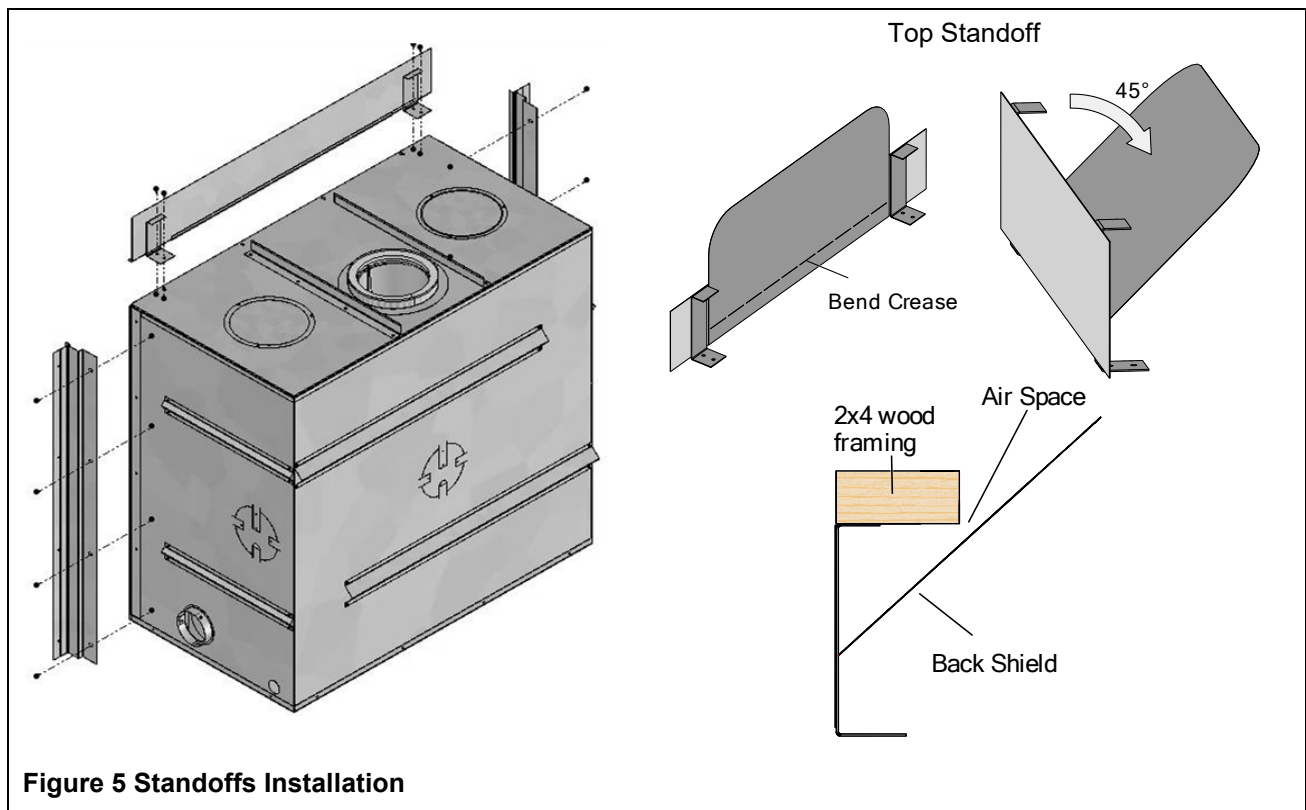

**Figure 5 Standoffs Installation**

Once the standoffs are in place, make sure to seal the ¼" gap between the fireplace and the standoffs with silicone sealant. **DO NOT** fill the gap behind the sealant with insulation or any other material.

### **SECURING THE FIREPLACE IN PLACE**

The fireplace **MUST** be attached to the floor.

Using the four small brackets that were securing the fireplace to the crate, attach the casing or base of the fireplace to the floor. Position the brackets all around the fireplace in the same fashion as they were on the crate. If possible, try to have at least one of the brackets screwed into the floor joists with 2" wood screws.

### **OUTSIDE AIR DUCT**

After the fireplace is correctly positioned, connect the outside air inlet to the fireplace.

Use an insulated aluminium flexible duct rated at over 200° F. The duct should not exceed 12' vertical rise above the base of the unit. We suggest using the 4" RSF outside air kit (FO-INT).

**The air inlet should always be at least 5' lower than the chimney rain cap and must never terminate in attic spaces.**

A 4" diameter duct can be used if the total duct run is less than 25'. For longer runs, use 5" diameter duct. Both 4" and 5" connecting sleeves are provided with the fireplace.

1. Find a convenient location for the insulated flexible duct and outside air inlet. The outside air inlet can be above or below floor level (see Figure 6).
2. Make a 4 ¼" (5 ¼" if using a 5" diameter duct) hole in the outside wall of the house. Push the outside

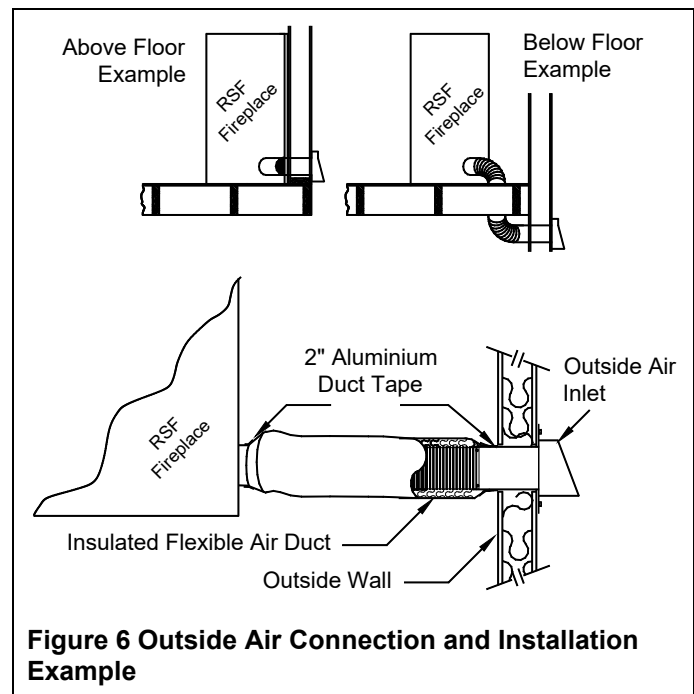

**Figure 6 Outside Air Connection and Installation Example**



air inlet in from the outside. Seal the joint between the air inlet and the outside wall with an appropriate sealant.

- Place the insulated flexible duct over the round sleeve on the outside air inlet. At both ends, carefully pull back the insulation and plastic cover, exposing the flexible duct. Then at each end, attach the duct with metal screws to the air inlet and to the fireplace connecting sleeve. Carefully push the insulation and cover back over the duct. Tape the plastic cover in place with 2" aluminium duct tape.

You can make a cold air trap by looping the outside air duct as shown in Figure 3 and Figure 4.

**❖ CAUTION: WHEN RUNNING THE DUCT AROUND CORNERS, BE SURE TO PREVENT CRIMPING THE DUCT IN A WAY THAT WOULD RESTRICT THE COMBUSTION AIR FLOW.**

### **MANDATORY OPTIONS**

Do not forget to install the louvers (FO-F320SBRLB) or the Clean Face Option (FO-F2) along with the two required Gravity Vent Kits (FO-V2 or FO-V3).

### **CHIMNEY**

This fireplace is certified for use with 7" ICC Model EXCEL chimney only. Please refer to Table 1 (D-E) for the minimum and maximum chimney height permitted with your fireplace.

We recommend that the minimum height be increased by approximately 6" for every 1000' elevation above sea level. Every 15°, 30° or 45° offset (one pair of elbows) also increases the minimum height. 45° elbows are not allowed in the USA. See Table 3 for more precise recommended flue heights.

For example, if you are living 6015' above sea level, your chimney should terminate at least 15' from the top of the fireplace if it is a straight chimney or at least 18'6" if one 30° offset is used as shown in Table 3.

**Table 3 Minimum Recommended Flue Heights**

Elevation (ft)	Number Of Offset						
	Straight Chimney	1 x 15°	2 x 15°	1 x 30°	2 x 30°	1 x 45°	2 x 45°
0 - 1000	Minimum 12'	13'	14'	15'	18'	16'	20'
1001 - 2000	12'6"	13'6"	14'6"	15'6"	19'	16'6"	20'
2001 - 3000	13'	14'	15'	16'	19'6"	17'	21'6"
3001 - 4000	13'6"	14'6"	15'6"	17'	20'	18'	22'6"
4001 - 5000	14'	15'	16'	17'6"	21'	18'6"	23'
5001 - 6000	14'6"	15'6"	17'	18'	21'6"	19'	24'
6001 - 7000	15'	16'	17'6"	18'6"	22'	20'	24'6"
7001 - 8000	15'6"	16'6"	18'	19'	23'	20'6"	25'6"
8001 - 9000	16'	17'	18'6"	20'	24'	21'	26'6"
9001 - 10000	16'6"	17'6"	19'	20'6"	24'6"	22'	27'

Flue height is measured from the top of the fireplace to the top of the chimney before installing the rain cap.

If you have two different offsets (two pairs of different elbows), simply use the column for two offsets of the biggest pair of elbows at your elevation to get your Minimum Flue Height.

## **CHIMNEY INSTALLATION**

Make sure to read the EXCEL Chimney installation manual concerning requirements for supports, bracing, anchors, etc. The EXCEL Chimney manual is available at your RSF dealer or on our web site: [www.icc-rsf.com](http://www.icc-rsf.com). Refer to Table 1 (F) for the maximum chimney height that can be supported by the top of the fireplace.

❖ **WARNING: THE CLEARANCE BETWEEN THE CHIMNEY AND COMBUSTIBLE MATERIAL MUST BE 2" OR MORE. DO NOT FILL THIS AREA WITH INSULATION.**

1. Cut and frame the required holes in the floor(s), ceiling(s) and roof where the chimney will pass through. The rough opening in the framing is 13" square (the opening can be slightly bigger, but NEVER smaller).
2. From below, install a radiation shield in each floor through which the chimney passes. At the attic level, install a radiation shield and a storm collar as shown in Figure 7.

❖ **WARNING: A RADIATION SHIELD MUST BE INSTALLED AT EACH FLOOR WHERE THE CHIMNEY PASSES THROUGH.**

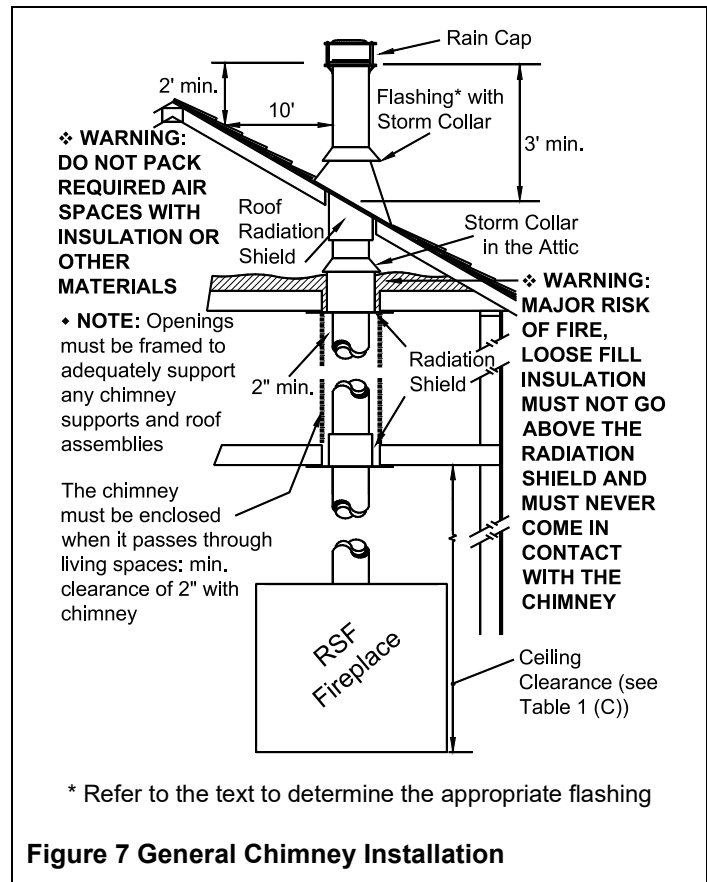

If you have a cathedral ceiling, consider using our radiation shield for cathedral ceiling (XM-7ERSC).

3. Place the first length of chimney on the fireplace. Secure the chimney length to the fireplace with the three screws provided. Assemble the rest of the chimney.

The chimney must extend at least 3' above its point of contact with the roof and at least 2' higher than any wall, roof, or building within 10' of it. If the chimney is higher than 5' above the roof, it must be secured using a roof brace.

4. **At the roof, install a roof radiation shield (XM-7ERRS). The roof radiation shield must be installed so it extends 1" above the roof line.**
5. Put the roof flashing into place.
  - **If the chimney is enclosed to the roof: use a vented flashing .**
  - **If the chimney is not enclosed to the roof: use a regular flashing.**
6. Seal the joint between the roof and the flashing with roofing tar. For sloping roofs, place the flashing under the upper shingles and on top of the lower shingles. Nail the flashing to the roof using roofing nails.
7. Place the storm collar over the chimney and flashing. Seal it around the chimney with silicone sealer (**DO NOT use roofing tar**).
8. Fit the rain cap on the chimney. Secure it tightly in place.

## **OFFSET CHIMNEY**

An elbow may be installed directly on top of the fireplace if required. See the detailed offset charts in the EXCEL chimney installation manual. Use the offset option if you need to clear a joist or pass around a cupboard. See Figure 8 and Figure 9 for examples.

- Maximum offset angle:
  - In **USA**: 30°
  - In **Canada**: 45°
- Maximum number of elbows: four, resulting in two offsets and returns.

Install the fireplace and chimney as described earlier. When you require an elbow, proceed as follows:

1. Install the required elbow. Turn it in the desired direction, and fasten it to the chimney length with the three metal screws provided at the joints.
2. Install enough lengths to obtain the desired offset. Secure each joint with three metal screws. Refer to the offset charts provided with the EXCEL chimney installation manual for exact offset dimensions.
3. Use another elbow to return the chimney to the vertical direction.
4. Install a wall support, or an offset support above each offset to support the weight of the chimney (elbows are not designed to support the chimney above an offset).

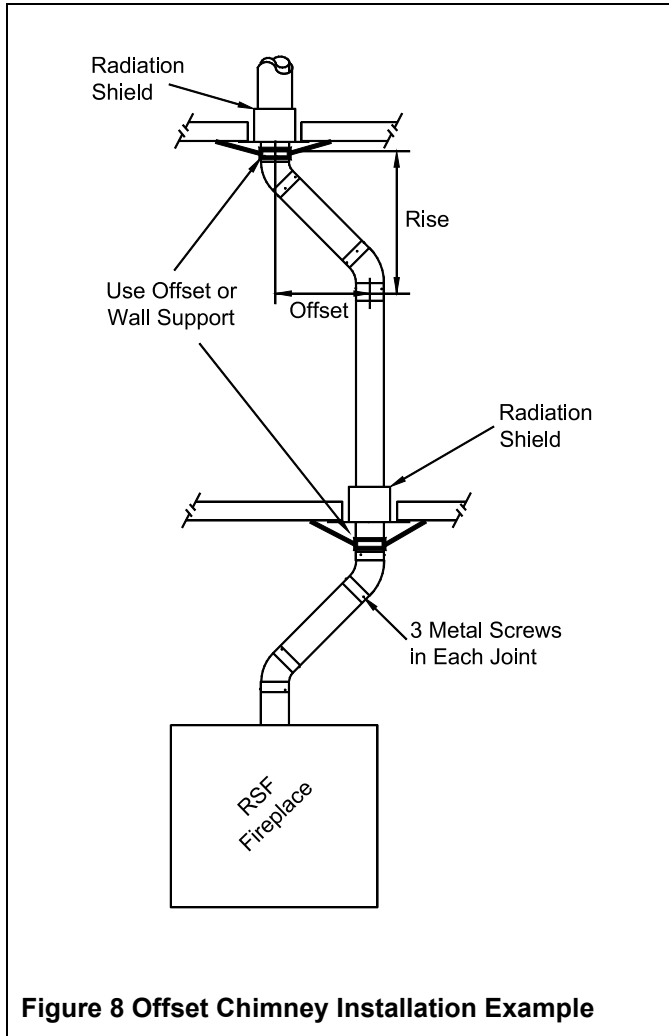

**Figure 8 Offset Chimney Installation Example**

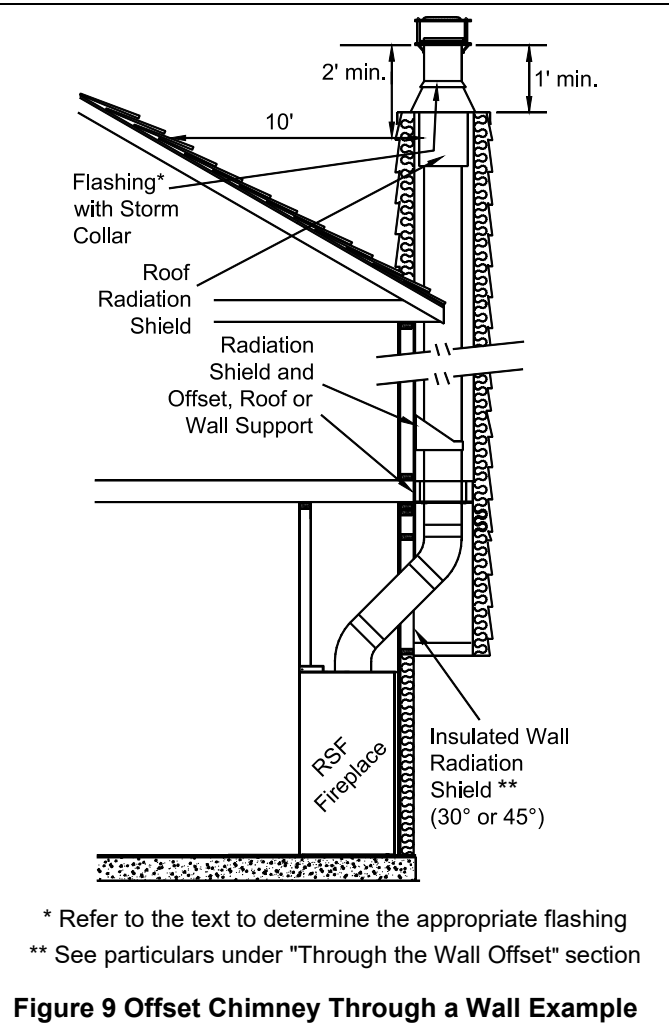

**Figure 9 Offset Chimney Through a Wall Example**

**Through the Wall Offset**

You can also go through the wall at an angle starting directly at the fireplace as depicted in Figure 9. An angled wall insulated radiation shield (XM-7EWRSI30 or XM-7EWRSI45) must be used wherever the chimney passed through an exterior wall. Make sure you have enough ceiling height. If not, you might want to consider installing the fireplace in an outside chase.

**If the chimney is enclosed once outside of the house, do not install the outside plate of the angled wall insulated radiation shield.**

Refer to the angled wall insulated radiation shield installation sheets for more detailed installations instructions.

## **CHASE ENCLOSURE**

If the chimney runs up the outside of the house, we recommend that it be enclosed in a chase structure. The chase should be constructed in such a way that it is an extension of the home (see Figure 10). It should be well insulated between the footings and the floor of the home to prevent heat loss. If the climate in your area is mild, insulate the chase at least to the first firestop. If the climate in your area is very cold, insulate the chase to the top to keep the chimney warmer, increase the draft, and reduce creosote buildup. We also recommend insulating the ceiling of the chase just as if it were in the attic space. This will prevent cold air from dropping down through the chase and into the room where the fireplace is installed (see Figure 10).

Some local codes require that the walls be insulated, vapor sealed and sheathed with a fire rated gypsum board (see Figure 10). We strongly recommend this procedure for all installations to prevent cold drafts from originating in the fireplace enclosure. If you follow this procedure, we recommend that you do not insulate the wall above the front of the fireplace.

♦ **REMEMBER:** Check local codes concerning installation requirements and restrictions in your area.

## **MASONRY CHIMNEY**

Installing your fireplace with a masonry chimney still requires using EXCEL chimney from the top of the fireplace to where it will connect to a listed liner that will run up inside the masonry chimney (see Figure 11).

The stainless-steel liner should be fitted inside the clay liner all the way to the top of the masonry chimney. It is not meant to replace the clay liner. You can use either the EXCEL liner or any other listed liner to ULC-S635, ULC-S640 or UL-1777.

Special care is to be taken to make sure that you have a good solid connection between the EXCEL chimney and the liner. A masonry adaptor (FO-FDM7) was designed specifically for that purpose and is available from your RSF dealer. It will attach to the liner with 3 stainless steel rivets (provided) and to the EXCEL chimney with 3 screws (provided).

After mortaring in place, the connection between the EXCEL chimney and the liner should not be visible in order to isolate the heat released through the liner from the fireplace enclosure.

As depicted in Figure 11, you must install at least one 18" length of EXCEL chimney after the EXCEL chimney elbow. The uppermost part of the EXCEL chimney - where it enters the masonry chimney - must be a minimum of 12" from the ceiling.

♦ **NOTE:** If the ceiling is high enough, you can install one or more EXCEL chimney lengths directly on the fireplace before the elbow.

If you use a flexible liner, make sure to be careful when cleaning to ensure that the stainless-steel flexible liner is not dislodged in any way.

## **Using an Existing Masonry Chimney**

❖ **WARNING: IF YOU ARE CONSIDERING USING AN EXISTING CHIMNEY, IT MUST FIRST BE THOROUGHLY INSPECTED BY AN AUTHORITY HAVING JURISDICTION TO DETERMINE THE FOLLOWING:**

- The masonry chimney is well constructed and fully lined, in accordance with Local Building Codes and the National Building Code of Canada (NBC) or National Fire Protection Association chimney standard (NFPA 211).

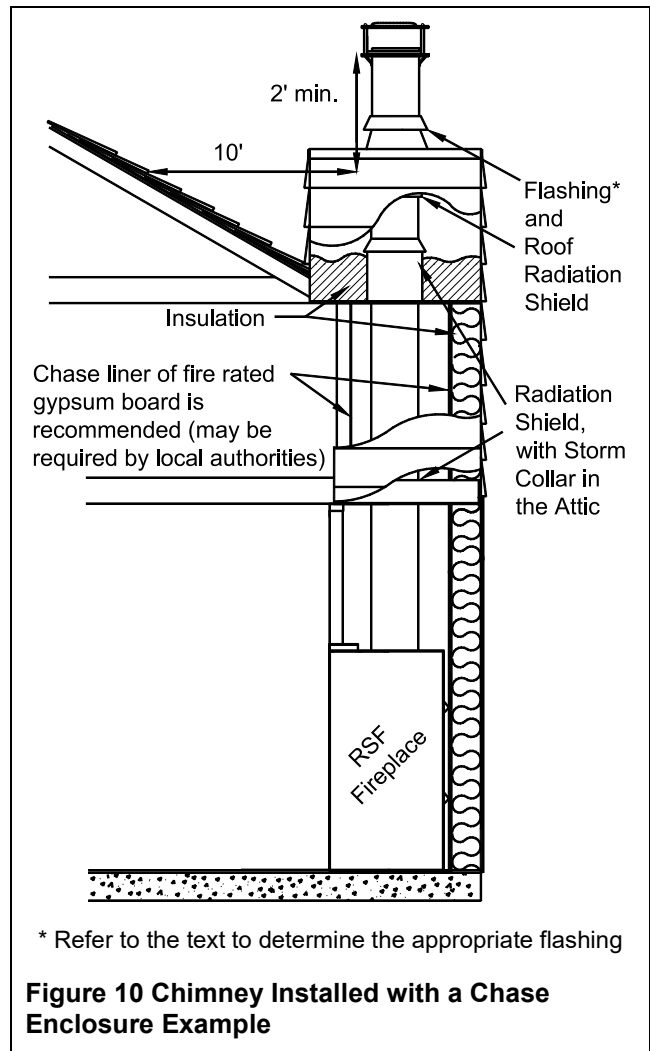

**Figure 10 Chimney Installed with a Chase Enclosure Example**

- It has been thoroughly cleaned of any soot or creosote residue and inspected to determine that it is in good working condition.
- There is no insulation of any type in contact with the masonry chimney and there is no insulation stuffed anywhere in the chimney.
- All the necessary clearances around the masonry chimney, along the complete run of the chimney, are respected as per NBC or NFPA 211. If the masonry chimney is enclosed in drywall, openings will probably be required in order to verify clearances at all points.

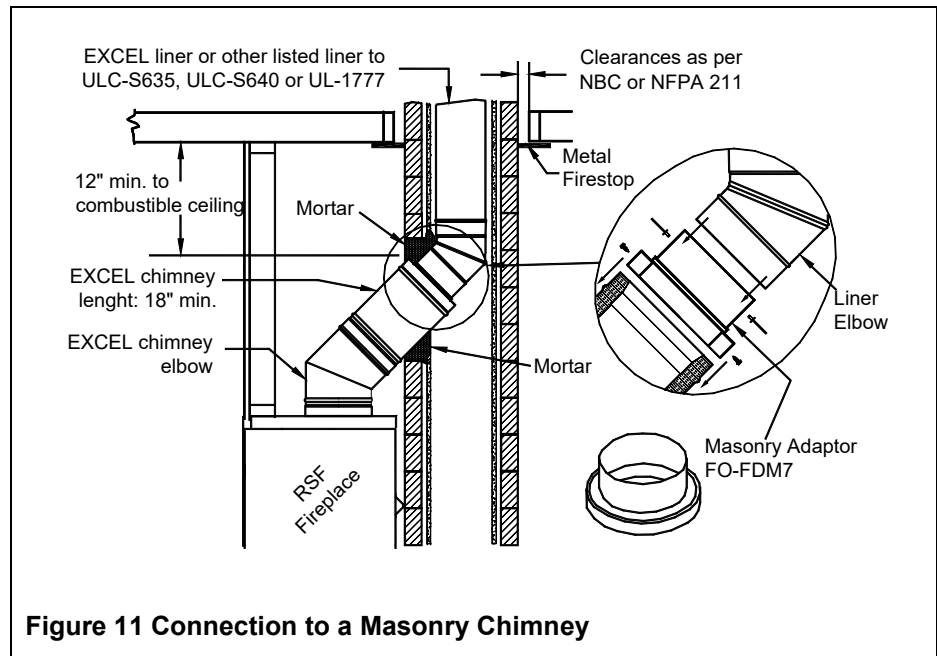

**Figure 11 Connection to a Masonry Chimney**

- The masonry chimney will only be used for the fireplace and no other appliance.

If major repairs are required to meet the above conditions, a new chimney should be constructed.

To make the hole through the masonry chimney and make the connection to the fireplace, we recommend that you follow these steps:

1. Sight-in and mark the outline of where the EXCEL chimney will penetrate the masonry chimney.
2. Using a large ( $\frac{3}{4}$ " - 2") masonry drill bit, drill a hole exactly in the center of the oval outline. With a masonry hammer and drill, slowly enlarge the hole to the size required. Remember to work from the center out. Be especially careful with the clay liner behind the brick because three sides of it must stay in place.
3. Bring the stainless-steel liner down from the top of the chimney.

If you are using a rigid liner you will need enough room to secure an elbow to it with at least two screws.

If it is difficult to install rigid stainless-steel liner in the existing masonry chimney or for a masonry chimney with less than 10"x10" inside, a listed stainless-steel flexible liner can be used along with a flexible/rigid adaptor (LM-7LAF) available from your RSF dealer.

4. Install the liner elbow and masonry adaptor on the lower end of the liner.
5. Move the fireplace forward enough to install the EXCEL chimney on the fireplace (elbow and length) then move the fireplace back into position as you connect the masonry adaptor to the EXCEL chimney.

### **Using a New Masonry chimney**

Since the masonry chimney is not build yet, we recommend that you position your fireplace, install the EXCEL chimney on it and connect to the first length of liner before building the chimney as explained above and shown in Figure 11 . The liner sections can easily be installed as the layers of brick are being placed. Since this is a new chimney, we recommend that you build it to the right size, so you do not have to ovalize the liner.

♦ **Remember:** The stainless-steel liner should be fitted inside the clay liner all the way to the top of the masonry chimney. It is not meant to replace the clay liner.

### **COVERING THE FIREPLACE FACING**

Facing materials (see Figure 3 and Figure 4) **MUST BE NON-COMBUSTIBLE** such as metal, brick, slate or ceramic tile. Gypsum board is **NOT** an acceptable facing material. Gypsum board cannot get closer to the fireplace than the side and top standoffs.

Facing this fireplace can be as simple as using cement boards that will be painted or gluing ceramic tiles with high temperature silicone sealant.

### **MANDATORY OPTIONS WITH THE CLEAN FACE**

When installing a Clean Face (FO-F2) on your FOCUS 320 SBR, you MUST install the intake duct (part of FO-F2) to provide sufficient air to the unit along with two Gravity Vent Kits (FO-V2 or FO-V3, sold separately) to provide an evacuation path for the heat. Neglecting to install either one of these will result in overheating of the unit and may put your safety at risk. Refer to each option's installation instructions for particular details.

Use only genuine RSF parts. The use of any substitutes will void the warranty and may put your safety at risk.

### **HEARTH EXTENSION**

The area immediately in front of the fireplace must be protected by a non-combustible material such as brick, tile, stone, or slate. Refer to Table 1 (G-H) for the depth and width that the hearth protection should extend beyond the front and both sides of the door opening (see Figure 1). There is no minimum thickness required for the hearth extension.

### **BENEATH HEARTH EXTENSION**

If your fireplace is installed on a non-combustible floor, the spark guard specified below is not required.

Install the spark guard provided (5" x 36" piece of sheet metal) halfway under the fireplace and halfway under the hearth extension and centered on the door opening. The spark guard will extend 2½" beneath the fireplace. This will make certain that sparks cannot lodge in this area and start a fire. If necessary, the provided spark guard can be cut to the minimum width specified in Table 1 (I).

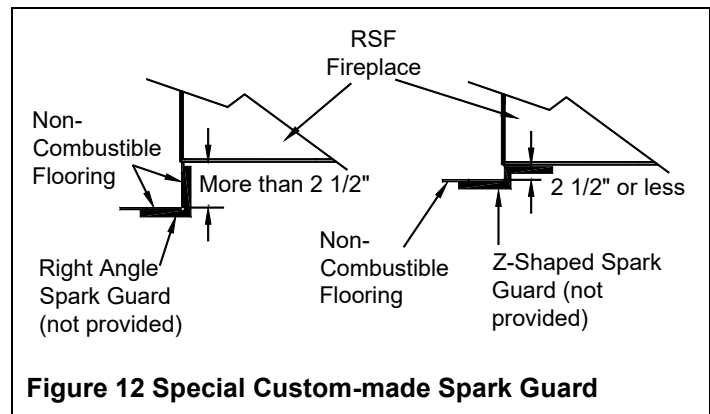

If you are preparing a raised installation, you will need a custom made spark guard, either a "Z" shaped spark guard or a right angle spark guard (see Figure 12). The Z-shaped spark guard must be used if the height between the bottom of the fireplace and the top of the non-combustible flooring of the hearth extension is less than or equal to 2½". The height of the Z-shaped spark guard must equal the distance between the floor and the base of the unit and go under the hearth extension and the fireplace by at least 2½". If the unit is installed higher than 2½" from the top of the flooring, a right-angle spark guard is necessary. The sides of the right-angle spark guard should be at least 2½" x 2½" and must be covered with non-combustible material. Any custom made spark guard must have the minimum width specified in Table 1 (I), and be installed centered on the door opening.

◆ **NOTE:** Custom-made spark guards are site built.

### **MANTEL**

Masonry and other non-combustible mantels (shelf and posts) can be placed anywhere around the fireplace opening, without blocking any of the bottom and top louvers. If the non-combustible mantel is located between the top of the fireplace facing and the specified height for a combustible mantel, then the wall portion between the top of the fireplace facing and the mantel must be covered in non-combustible material. If the non-combustible mantel is located at the same height allowed for a combustible mantel, or higher, then no special wall covering is required below the mantel.

For combustible mantels shelves, please see Table 1 (J-K) for the maximum depth of the mantel shelf and their clearance requirements. See Figure 1 for an example.

Vertical mantel posts on the sides of the fireplace opening must be non-combustible. Combustible mantel posts are not permitted unless they meet the clearance required to a perpendicular sidewall (see Table 1 (B)).

## **REFRACTORY BRICK INSTALLATION**

The refractory bricks for the FOCUS 320 SBR fireplace are placed in the fireplace at the factory. If, for any reason, they should need to be replaced the following order should be observed (see Figure 13). To remove any of the refractory bricks, just remove the andirons and then follow the installation procedure in the reverse sequence. Refer to Figure 13 to adequately identify which refractory brick is the right and which is the left at each step of the installation.

1. Start by installing both back refractory bricks (①). The brick pattern is slightly off centered on the brick. The longer partial bricks go towards the center of the firebox.
2. Then install both side refractory bricks (② on the left and ③ on the right).
3. Clean the bottom of the firebox and install both bottom refractory bricks (④ on the left and ⑤ on the right).
4. Continue by installing the front refractory brick (⑥).

These refractory bricks have been designed specifically for your fireplace and no modifications are required to ensure a proper fit.

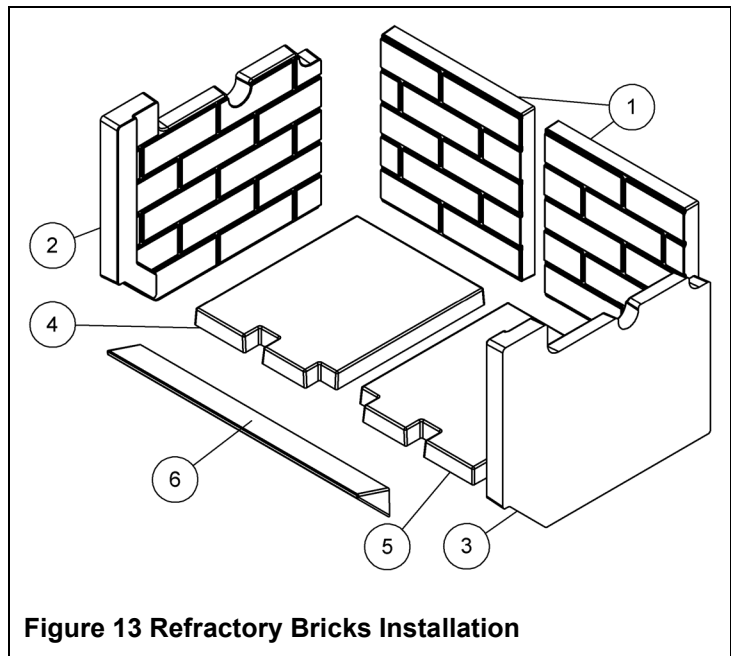

**Figure 13 Refractory Bricks Installation**

## **BAFFLE**

The baffle is made of a sandwich of 3 different materials. Each is required for proper operation of the fireplace. If the baffle needs to be replaced, proceed with care. The following steps are to install a new baffle:

1. First, the refractory bricks should be removed from the firebox as well as the front secondary air tube at the top front of the firebox by removing the cutter pin located on the left side of the front tube.
2. Then gently slide the rigid grey baffle above the secondary air tubes. Be careful it is fragile. It should be centered from left to right, and close to where the front secondary air tube will be once reinstalled.
3. Place the soft white insulation on top of the baffle, making sure to push it against the far back and the sides of the firebox. You will need to gently squash it down in place. It is cut slightly bigger than the surface to cover to ensure that it seals the entire area above the grey baffle.
4. Then place the steel shield on top of the soft white insulation. The bend should face forward and up, and rest centered against the back of the front secondary air tube. Be careful to lift the shield so it does not rip the soft white insulation apart.
5. Reinstall the first tube and screw it in place.
6. Make sure that all three layers are against the back of the front secondary air tube.
7. You can now reinstall the refractory bricks.

# LISTING LABEL

The listing label is glued to the bottom of the fireplace. Just remove the bottom louver, the listing label is below the floor shield.

**LISTED FACTORY FIREPLACE AND SPACE HEATER**  
**MODEL: FOCUS 320 SBR**  
 TESTED TO:  
 UL 1277 / CANULC-S810 / CANULC-S627  
 EPA 2020 CRIB WOOD, CERTIFIED AT 1.4 G/H  
 INSTALL AND USE ONLY IN ACCORDANCE WITH THE MANUFACTURER'S INSTALLATION AND OPERATING INSTRUCTIONS. **DO NOT OBSTRUCT COMBUSTION AIR INLET.** DO NOT USE A FIREPLACE INSERT OR OTHER PRODUCTS NOT SPECIFIED FOR USE IN THIS PRODUCT. OPERATE WITH DOOR FULLY OPEN OR FULLY CLOSED. SUITABLE FOR TRANSPORTABLE BUILDING INSTALLATION.

MINIMUM CLEARANCES TO COMBUSTIBLE MATERIALS
SIDEWALL 12 IN. (305 mm) FROM FIREBOX OPENING
*HEIGHT OF MANTLE SHELF: MAX. 12 IN. (305 mm) DEEP
UNIT BACK, SIDES AND BOTTOM 0 IN. (0 mm) TO SPACERS

\* SEE INSTALLATION INSTRUCTIONS FOR OTHER MANTLE HEIGHTS VS DEPTHS. COMBUSTIBLE MATERIALS ARE NOT PERMITTED ON FACE OF UNIT. NON-COMBUSTIBLE HEARTH EXTENSION MUST BE 20 IN. (508 mm) DEEP BY 42 IN. (1070 mm) WIDE, AS SPECIFIED IN THE INSTALLATION MANUAL.

COMPONENTS REQUIRED FOR INSTALLATION:  
 - USE 4 IN. OR 5 IN. (102 OR 127 mm) DIAMETER FLEXIBLE DUCT AND COMBUSTION AIR INLET ASSEMBLY.  
 - USE THE ICC MODEL 7 IN. (178 mm) EXCEL CHIMNEY AND LISTED COMPONENTS AS PER INSTALLATION INSTRUCTIONS.

REFER TO MANUFACTURER'S INSTALLATION AND OPERATING INSTRUCTIONS FOR OPTIONAL COMPONENTS: FANS, GRAVITY VENT SYSTEM AND CENTRAL HEATING ACCESSORIES. ONLY ORIGINAL RSF OPTIONS SHOULD BE USED WITH THIS FIREPLACE, AND PURCHASED THROUGH RSF DEALERS.

WARNING: THIS FIREPLACE HAS NOT BEEN TESTED WITH AN UNVENTED GAS LOG SET. TO REDUCE RISK OF FIRE OR INJURY, DO NOT INSTALL AN UNVENTED GAS LOG SET INTO THE FIREPLACE.

REPLACE GLASS ONLY WITH 5 mm CERAMIC GLASS. OPERATE ONLY WITH FIREBRICK IN PLACE. FOR USE WITH SOLID WOOD FUEL ONLY. DO NOT OVERTIRE UNIT.

THIS WOOD HEATER NEEDS PERIODIC INSPECTION AND REPAIR FOR PROPER OPERATION. CONSULT THE OWNER'S MANUAL FOR FURTHER INFORMATION. IT IS AGAINST FEDERAL REGULATIONS TO OPERATE THIS WOOD HEATER IN A MANNER INCONSISTENT WITH THE OPERATING INSTRUCTIONS IN THE OWNER'S MANUAL.

THIS SINGLE BURN RATE WOOD HEATER IS NOT APPROVED FOR USE WITH A FLUE DAMPER OTHER THAN AN OPEN-CLOSE FLUE DAMPER.

**NE PAS ENLEVER CETTE ÉTIQUETTE**  
 CERTIFIÉ CONFORME PAR EPA (É.-U.) AUX NORMES 2020 D'ÉMISSION DE PARTICULES POUR LES APPAREILS À TAUX DE COMBUSTION UNIQUE EN UTILISANT UNE CHARGE NORMALISÉE.

INSTALLER ET UTILISER SELON LES INSTRUCTIONS D'INSTALLATION ET DE FONCTIONNEMENT DU MANUFACTURIER. **NE PAS OBSTRUER L'ENTRÉE D'AIR COMBUSTIBLE.** N'UTILISEZ PAS D'ENCASTRABLE OU AUTRES PRODUITS NON SPÉCIFIÉS POUR UTILISATION AVEC CE PRODUIT. FAIRE FONCTIONNER LE FOYER AVEC LA PORTE COMPLÈTEMENT OUVERTE OU FERMÉE. CONVIENT AUX BÂTIMENTS TRANSPORTABLES.

FOYER PRÉFABRIQUÉ ET APPAREIL DE CHAUFFAGE HOMOLOGUÉ  
**MODELÉ: FOCUS 320 SBR**  
 MIS À L'ESSAI SELON LES NORMES: UL 1277 / CANULC-S810 / CANULC-S627  
 CERTIFIÉ EPA 2020, CHARGE NORMALISÉE À 1.4 G/H

DÉGAGEMENTS MINIMAUX AUX MATÉRIEAUX COMBUSTIBLES
MUR DE CÔTÉ 12 PO. (305 mm) DE L'OUVERTURE DE LA BOÎTE À FEU
*HAUTEUR DE LA TABLETTE DE MANTEAU DE CHEMINÉE: MAX. 12 PO. (305 mm) DE PROFONDEUR
ARRIÈRE, CÔTÉS ET BASE DE L'APPAREIL 0 PO. (0 mm) DES ESPACEURS

\* VOIR LE MANUEL D'INSTALLATION POUR AUTRES HAUTEURS VS PROFONDEURS DE LA TABLETTE. LES MATÉRIEAUX COMBUSTIBLES NE SONT PAS PERMIS SUR LA FAÇADE DE L'APPAREIL. LE PROLONGEMENT DE L'ÂTRE INCOMBUSTIBLE DOIT ÊTRE DE 20 PO. (508 mm) DE PROFONDEUR PAR 42 PO. (1070 mm) DE LARGEUR MINIMUM SUIVANT LES SPÉCIFICATIONS DU MANUEL D'INSTALLATION.

PIÈCES REQUISES POUR L'INSTALLATION:  
 - TUYAU FLEXIBLE DE 4 PO. OU 5 PO. (102 OU 127 mm) DE DIAMÈTRE ET PRISE D'ENTRÉE D'AIR.  
 - UTILISER UNE CHEMINÉE EXCEL 7 PO. (178 mm) DE DIAMÈTRE DE ICC ET SES COMPOSANTS HOMOLOGUÉS SELON LES INSTRUCTIONS D'INSTALLATION.

VOIR LES INSTRUCTIONS D'INSTALLATION DU MANUFACTURIER POUR LES COMPOSANTS OPTIONNELS: VENTILATEURS, SYSTÈME D'ÉVENT PAR GRAVITÉ ET ACCESSOIRES DE CHAUFFAGE CENTRAL. SEULES LES OPTIONS ORIGINALES DE RSF DOIVENT ÊTRE UTILISÉES ET ACHETÉES PAR L'ENTRÉE DE DÉTAILLANTS RSF.

AVERTISSEMENT: CE FOYER N'A PAS ÉTÉ TESTÉ AVEC UNE BÛCHE À GAZ SANS ÉVÈNT. POUR RÉDUIRE LES RISQUES DE FEU ET DE BLESSURES, NE PAS INSTALLER DE BÛCHE À GAZ SANS ÉVÈNT DANS CE FOYER.

LE REMPLACEMENT D'UNE VITRE DOIT SE FAIRE AVEC UNE VITRE CÉRAMIQUE DE 5 mm D'ÉPAISSEUR SEULEMENT. OPÉRER SEULEMENT AVEC LES PIÈRES REFRACTAIRES EN PLACE. POUR UTILISATION AVEC DU BOIS SEULEMENT. NE PAS SURCHAUFFER L'APPAREIL.

CET APPAREIL AU BOIS DOIT ÊTRE INSPECTÉ PÉRIODIQUEMENT ET MAINTENU EN BON ÉTAT DE FONCTIONNEMENT. RÉFÉREZ-VOUS AU MANUEL DU PROPRIÉTAIRE POUR PLUS D'INFORMATIONS. IL EST INTERDIT PAR LES LOIS FÉDÉRALES D'OPÉRER CET APPAREIL AU BOIS SANS RESPECTER LES CONSIGNES D'OPÉRATION DU MANUEL DU PROPRIÉTAIRE.

CET APPAREIL AU BOIS N'EST PAS APPROUVÉ AVEC UN REGISTRE DE CHEMINÉE AUTRE QU'UN REGISTRE OUVERT-FERMÉ.



UL  
SAFETY US-CA  
SECURITE US-CA  
MH01405



SERIAL NO. / NO DE SERIE

DATE MANUFACTURED  
DATE DE FABRICATION

MANUFACTURED BY /  
FABRIQUE PAR:  
ICC, 400 J.F. KENNEDY,  
ST-JEROME, QC,  
CANADA, J7Y 4B7



MADE IN CANADA  
FABRIQUE AU CANADA

FOR USE WITH ICC CERTIFIED MODEL RESIDENTIAL TYPE AND BUILDING HEATING APPLIANCE CHIMNEY

FIREPLACE: FIRE CHAMBER  
FOR USE WITH ICC CERTIFIED MODEL RESIDENTIAL TYPE AND BUILDING HEATING APPLIANCE CHIMNEY

NUMBER





 <b>FIREPLACE OPTIONS</b>	⚡											
	Electricity required	DELTA FUSION	FOCUS 320	FOCUS 320 SBR	FOCUS 3600	FOCUS ST	OPEL2 & OPEL3	OPEL+2C & OPEL+3C	OPEL+KEYSTONE	PEARL 3600		

OPTIONAL ADDITIONAL ACCESSORIES												
UL127 & ULC-S610 Listed												
FO-FDHC6	Central Heating Control (with FO-FDHB6-1)	⚡	✓	✓	✓				✓	✓	✓	
FO-FDHC6-1	Back Draft Damper		✓	✓	✓				✓	✓	✓	
FO-FDHCZ1	Zone Heating Control (with FO-FDHB6-1)	⚡	✓	✓	✓				✓	✓	✓	
FO-FDHCZ2	Zone Definition Kit (with FO-FDHB6-1)	⚡	✓	✓	✓				✓	✓	✓	
FO-T	Central Heating Tee Option		✓	✓	✓				✓	✓	✓	

MISCELLANEOUS OPTIONS												
UL127 & ULC-S610 Listed												
FO-AP	Ash Pan - Regular								✓	✓	✓	
FO-CID	Intake Duct Kit - 6" (necessary for FO-CIF)											
FO-CATP	OpelC-OpelPlus-Keystone									✓	✓	
FO-FDCCO	Opel Catalytic Kit								✓			
FO-FDM6	Brick Chimney Adapter - 6"					✓						✓
FO-FDM7	Brick Chimney Adapter - 7"			✓	✓				✓	✓	✓	
FO-FDM8	Brick Chimney Adapter - 8"		✓						✓			

MISCELLANEOUS OPTIONS												
Not listed - No impact on safety												
FO-A	Decorative Log Retainer Cap		✓	✓	✓			✓	✓	✓	✓	
FO-BRE	Bypass Rod Extension									✓		
FO-DTD	Digital Temperature Display									✓	✓	
FO-FDS45	45° Nailing Bracket		✓									
FO-INT	Outside Air Kit - 4" diameter		✓	✓	✓			✓	✓	✓	✓	✓
FO-KDF	Rock Retainer Kit - Delta Fusion		✓									
FO-KFSBR	Rock Retainer Kit - F320 & F320SBR			✓	✓							
FO-KK	Rock Retainer Kit - Keystone											✓
FO-KN	Rock Retainer Kit - Onyx2/F320			✓								
FO-KP3	Rock Retainer Kit - Opel2/+2C/Opel3/+3C									✓	✓	
FO-KR	Rock Retainer Kit - Focus ST								✓			
FO-PDTB	Opel3 - Decorative Trim - Black									✓	✓	
FO-PDTG	Opel3 - Decorative Trim - Gold									✓	✓	
FO-PDTP	Opel3 - Decorative Trim - Pewter									✓	✓	

## CONFIGURED OPTIONS LIST

<b>Clean Face FOCUS 320 SBR</b>	<b>Required</b>	<b>Optional</b>	<b>Not available</b>
Clean Face Option	FO-F2		
Gravity Vent Kit	FO-V2 (2) or FO-V3 (2)		
Inline Fan		FO-CIF	
Blower – Central Heat		FO-FDHB6-1*	
Heat Dump Kit		FO-HD	
Rock Retainer Kit		FO-KN	
Central Heat T Option		FO-T	
Blower (internal fan)			FO-HB9

<b>Louvered FOCUS 320 SBR</b>	<b>Required</b>	<b>Optional</b>	<b>Not available</b>
Blower (internal fan)		FO-HB9	
Blower - Central Heat		FO-FDHB6-1*	
Heat Dump Kit		FO-HD	
Rock Retainer Kit		FO-KN	
Central Heat T Option		FO-T	
Gravity Vent Kit		FO-V2 (1 or 2) or FO-V3 (1 or 2)	
Inline Fan			FO-CIF

\* Possible add-ons: FO-FDHC6, FO-FDHCZ1, FO-FDHCZ2

# REPLACEMENT PARTS

Use only genuine RSF parts. The use of any substitutes will void the warranty and may put your safety at risk.

**1. Louver**

**3. Door Glass**  
(Includes glass and door gaskets)

**Focus SBR**

**Index - Focus SBR part codes**

Number	Codes	Description
1	FR-99.10.01.SBR	Louver (1 piece)
2	FR-99.09.03.SBR	Complete door assembly
3	FR-99.09.02.SBR	Door glass and gaskets
4	FO-GRK8	Door gasket replacement kit 5/8"
5	FR-98.09.06	Glass gasket - 1/8" thick x 3/8" wide
6	FR-14.6.1	Wood handle
7	FR-99.09.01.SBR	Door handle assembly
8	FR-99.09.04.FB	Door hinges (2)
9	FR-1.6.1.N	Side stand offs (2)
10	FR-99.06.01	Top stand off

WOODBURNING FIREPLACES

DATE: 2022-09-14  
REV: 1  
Page: 1 of 2

## 11. Complete Refractory Brick Set

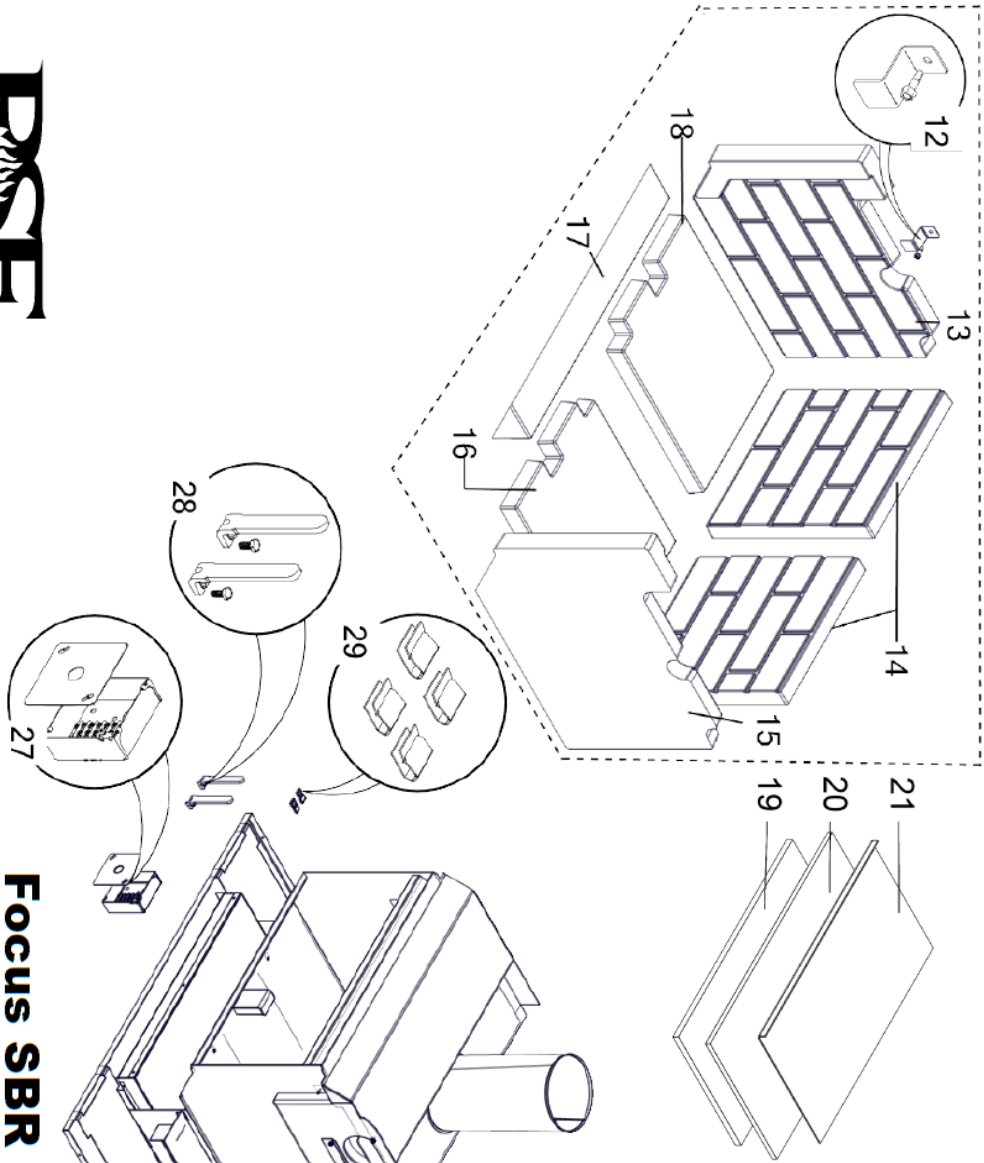

## Index - Focus SBR part codes

Number	Codes	Description
11	FR-99.11.01.FB	Complete refractory brick set
12	FR-98.11.08.FB	Side refractory bracket (2)
13	FR-98.11.02.FB	Left refractory brick
14	FR-98.11.01.FB	Back refractory brick (2)
15	FR-98.11.03.FB	Right refractory brick
16	FR-98.11.05.FB	Bottom right refractory brick
17	FR-98.11.06.FB	Front refractory brick
18	FR-98.11.04.FB	Bottom left refractory brick
19	FR-98.11.20.SBR	C Cast baffle
20	FR-98.11.21.SBR	Ceramic wool baffle
21	FR-99.05.01.SBR	Metal plate for baffle
22	FR-7.2.DNP	Draft control gasket (2 required)
23	FR-99.07.01.SBR	Combustion air control
24	FR-99.07.04.SBR	Air tube pin & cotter pin
25	FR-99.07.03.SBR	Rear air tube with pin & cotter pin
26	FR-99.07.02.SBR	Front or center air tube with pin & cotter pin
27	FR-99.12.01.P	Terminal block
28	FR-99.12.01.FB	Log retainers and screws (2)
29	FR-98.12.01.SBR	Lower heat shield clips (4)



## LIMITED WARRANTY

### 30 Years Limited Warranty

**All RSF Woodburning Fireplaces models are warranted against defects in material and workmanship for a period of 30 years, subject to the following conditions:**

During the first year **RSF Woodburning Fireplaces** will repair or replace, at our option, any parts which upon examination by an authorized **RSF Woodburning Fireplaces** representative, are found to be defective, except the parts listed in the EXCLUSIONS portion of this warranty. **RSF Woodburning Fireplaces** will also pay reasonable labor costs for the repair work.

During the second through fifth years **RSF Woodburning Fireplaces** will repair or replace, at our option, any parts which upon examination by an authorized **RSF Woodburning Fireplaces** representative, are found to be defective, except the parts listed in the EXCLUSIONS portion of this warranty. **RSF Woodburning Fireplaces** shall not be responsible for any labor costs associated with this repair work.

During the sixth through thirtieth years **RSF Woodburning Fireplaces** will provide replacement parts, if available, at 50% of the published retail price, except for the parts listed in the EXCLUSIONS portion of this warranty. **RSF Woodburning Fireplaces** shall not be responsible for any labor costs associated with this repair work.

#### **EXCLUSIONS:**

- Electrical components are warranted for one year only.
- Glass.
- Andirons.
- Damage due to normal wear and tear, such as paint discoloration, worn gaskets, eroded or cracked refractory components.
- Repairs or replacements necessitated by vandalism, neglect, abuse, over-firing, improper fuel or fuel loads, or failure to adequately service the unit, as stated in the owner's manual.
- Repairs or replacements (particularly charges for travel and labor) not authorized by **RSF Woodburning Fireplaces** in advance.

#### **LIMITATIONS:**

- All items found to be defective will be replaced or repaired upon return of the defective part to an authorized **RSF Woodburning Fireplaces** dealer. **RSF Woodburning Fireplaces** will not be responsible for freight costs related to shipping replacement parts.
- Any complete fireplace, or part thereof, that is replaced or serviced under this warranty, will be warranted for a period not exceeding the remaining term of the original warranty.
- This warranty is not transferable.
- This warranty does not apply to damage to the appliance while in transit.
- This warranty does not apply if the installation does not conform to the installation requirements in the owner's manual.

**RSF Woodburning Fireplaces** is free of liability for any damages caused by the appliance, as well as material and labor charges incurred in the removal or re-installation of any **RSF Woodburning Fireplaces** fireplace under this warranty. Incidental or consequential damages are not covered by this warranty.

The remedies set forth herein are exclusive, and the liability of the seller shall not exceed the price of the fireplace or part thereof upon which the liability is based.

This warranty is expressly in lieu of all other warranties expressed or implied, including the warranties of merchantability and fitness for use and all other obligations or liabilities on the part of **RSF Woodburning Fireplaces**.